

Analytical Scientific Instruments

HPLC Instruments and Components

distributed by SOCOCHIM SA for Switzerland



Analytical Scientific Instruments

About ASI

ASI manufactures a broad range of instruments and components for High Pressure Liquid Chromatography (HPLC). While some of our products may appear rather routine at first glance, ASI instruments and components incorporate technology which is totally unique in the industry. The approach to product development at ASI has always been to “build a better mouse trap” to solve some of the most vexing problems that chromatographers face. Our solutions include: **ASI Self-priming Check Valves**, **HyperShear™ Static and Dynamic Mixers**, and fluid resistor based **QuickSplit™ Fixed and Adjustable Flow Splitters**. Whatever the product, the final test is customer satisfaction, so we go to great lengths to insure all ASI products work as advertised.

We can also apply our engineering and manufacturing expertise to develop **custom products** to meet your specific needs. ASI has worked with, and designed OEM products for most major HPLC manufacturers. Please let us know if we can provide components or subassemblies for your next HPLC project.

Engineering Expertise

If the design is not correct to begin with, then even the best manufacturing capability in the world can do no more than produce a well made product that doesn't work. At ASI, we apply a rigorous engineering analysis to our products before they go to the prototype stage. For our check valves, this entails stress and deflection analysis of critical components such as the seat, gaskets, and valve casing. A fluid flow analysis is then performed to make certain that the pressure drop across the valve is within proper limits. Finally, a tolerance study is performed on the design to insure that the parts fit together (it is here where 90 % of all designs fail!).

Once the prototype is built, we test it to verify that the performance matches the theory. Next, we build several production-like units that allow us to prove manufacturability, reliability, and most important of all, the consistency of the product performance and reliability over the specified range of manufacturing tolerances.

Manufacturing Capabilities

Good design is the essential starting point for performance and reliability, but a good design is useless without the manufacturing capability to execute it properly. For this reason, we have invested much time and money into our computer controlled machining centers, inspection equipment, and the experts to set up and operate this equipment properly. Many of our products are manufactured with dimensional tolerances that are equal to 1/50 of the diameter of human hair. While these tolerances are often tighter than our designs dictate, we believe that the resulting improvement in reliability and performance is well worth the added cost in manufacturing.

Quality Control and Final Test

We believe it is not possible to manufacture reliable valves or other fluidic devices without 100% inspection of all critical parts. That is why we inspect every critical dimension on every part that affects valve performance. But even with all this inspection, we know we're not perfect, so every mixer assembly or check valve that we ship is first subjected to a final test to prove that it performs properly under pressure.

What's New

QuickSplit™ Flow Splitters



Fixed Splitters Page 8



Adjustable Splitters Page 17

HyperShear™ HPLC Mixers

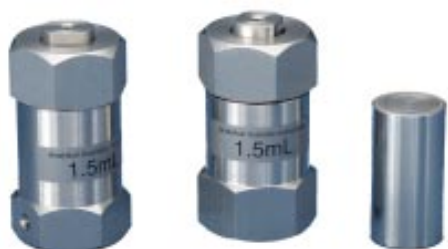

High Flow Static Mixers Page 44



Dynamic Mixers Page 51

FlatLine™ Pulse Damper



Page 32

HPLC Pumps



Page 25

Table of Contents

Ordering Information	2
About ASI	3
What's New	4
QuickSplit™ Flow Splitters	6
<i>QuickSplit</i> Fixed Flow Splitters	8
<i>QuickSplit</i> Adjustable Flow Splitters	17
<i>QuickSplit</i> Flow Splitter Accessories	24
HPLC Instruments	
ASI HPLC Pumps	25
ASI Post Column Reactor	29
FlatLine™ Pulse Damper	32
HyperShear™ HPLC Mixers	34
<i>HyperShear</i> Static Mixers	36
<i>HyperShear</i> Dynamic Mixers	51
ASI Replacement Parts for HPLC Pumps	52
ASI Self-priming Check Valves	54
ASI Replacement Piston Seals	56
ASI Replacement Pistons	57
Parts by Pump Manufacturer	58
Installing ASI Check Valves	102
Maintenance and Trouble Shooting Tips	103
Trouble Shooting Guide	106
ASI HPLC Accessories	110
In-Line Check Valves	111
Reference Manual for HPLC	111
Fittings and Unions	112
Filters	112
Tubing	114
High Pressure Metering Valve	114

***QuickSplit™* Flow Splitters**



***QuickSplit™* Flow Splitter Features:**

- Fluid resistor technology eliminates tedious adjustments to capillary tubing for split ratio optimization
- Split ratios are stable and reproducible, and not affected by changes in viscosity or pressure
- Adjustable metering valve enables precise direct control over split ratios
- Easy to use interchangeable fluid resistors make it possible to achieve split ratios from 1:1 to 20,000:1
- Applications include LC/MS, pre/post-column flow splitting, and flow fractionation
- Multiport flow splitter diverts the inlet flow into 3 or 4 channels for applications that employ multiple detectors and/or a fraction collector
- Rugged stainless steel construction allows high pressure operation
- Low dead volume fluidic design
- Unique flow path geometry resists clogging better than capillary tube resistors

QuickSplit™ Flow Splitters

The *ASI QuickSplit* Flow Splitter is very elegant in its simplicity. Split ratios are created by two or more fluid resistors that form a parallel flow path. *QuickSplit* Flow Splitters are available with a fixed or adjustable split ratio. Interchangeable fluid resistors make it easy to change split ratios quickly, eliminating tedious adjustments to capillary tubing. The technology can be applied to all applications where a controlled, reproducible split ratio is required including LC/MS, flow fractionation, pre/post-column flow splitting, and capillary chromatography. *ASI QuickSplit* Flow Splitters come in flow rate ranges which make them compatible with micro, analytical and preparative inlet flows.

Table of Contents

QuickSplit Fixed Flow Splitters	8
QuickSplit Binary Fixed Flow Splitters	
Post-Column Analytical	10
Post-Column Semi-Preparative	11
Pre-Column Analytical	14
QuickSplit Multiport Fixed Flow Splitters	
Post-Column Analytical	12
Post-Column Semi-Preparative	13
QuickSplit Makeup-Flow Splitter Manifold	13
<i>QuickSplit</i> Fixed Flow Splitter Performance Data	16
QuickSplit Adjustable Flow Splitters	17
Post-Column Analytical	19
Post-Column Semi-Preparative	20
Post-Column Preparative	20
Pre-Column Analytical	21
<i>QuickSplit</i> Adjustable Flow Splitter Selection Charts	22
QuickSplit Flow Splitter Accessories	24

QuickSplit Fixed Flow Splitters

QuickSplit™ Fixed Flow Splitter

Unlike conventional splitters that use long lengths of capillary tubing, the *ASI QuickSplit* Fixed Flow Splitter uses two compact fluid resistor elements which are designed as cartridges for easy replacement. *ASI* fluid resistors are analogous to resistors used in an electrical circuit. Resistance values (L) are rated in PSI/mL/min. Because of the extremely low internal volume of the fluid resistors, the solvent composition in both resistors at any instant in time is the same, and therefore viscosity changes associated with gradient runs do not impact the split ratio.

QuickSplit Fixed Flow Splitters provide a fixed split ratio with extremely low dead volume. Delay volume on the low flow rate side is as low as 100 nanoliters, depending upon the resistor cartridge selected. The split ratio is not affected by changes in solvent viscosity or pressure, and is extremely stable and reproducible. The interchangeable fluid resistors are available in a wide range of values which make it possible to create split ratios from 1:1 to as high as 20,000:1.

The flow path of the *QuickSplit* Fixed Flow Splitter contains two fluid resistors that form a parallel flow path. Both low and high flow rate streams pass through fixed resistor cartridges. The ratio of these two resistors creates the split ratio. To understand how the *QuickSplit* Fixed Flow Splitter works it helps to look at a diagram, figure 1, of the fluid resistors in relation to the flow paths and how a split ratio is calculated.

Figure 1. Schematic flow diagram of the *QuickSplit* Fixed Flow Splitter

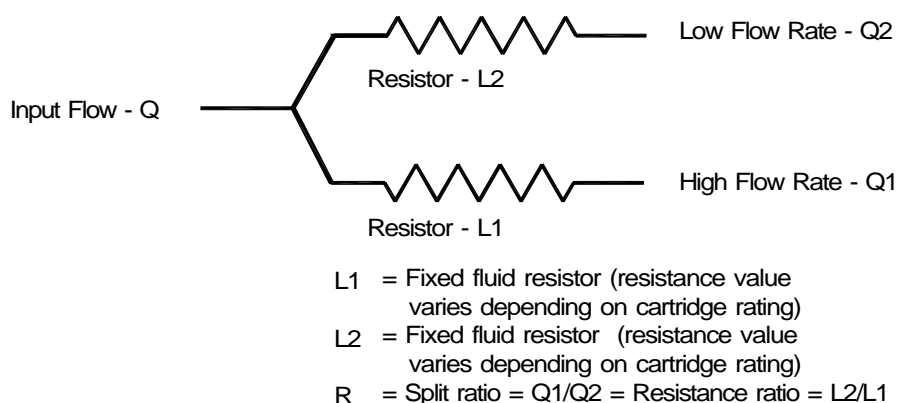

Since the flow rate is indirectly proportional to resistance, changing the resistance in either flow path results in a change to the split ratio. Changing resistance is accomplished by exchanging the fixed fluid resistor cartridges with a resistor set that has different resistor ratings.

The *QuickSplit* Fixed Flow Splitter is shipped with resistors installed that deliver the nominal stated split ratio. The split ratios have a tolerance range of +/- 10%. The exact split ratio is measured at *ASI* and is stated on the certificate shipped with the splitter. The input flow rate can be adjusted to compensate for the tolerance in split ratios. For instance, a 10% increase in input flow rate will result in a 10% increase in flow at both the low and high flow channels. Flow rate and viscosity changes will change the backpressure generated by the splitter, but will not affect the actual split ratio. The *QuickSplit* Fixed Flow Splitter is shipped configured for either post-column or pre-column applications.

QuickSplit™ Binary Fixed Flow Splitter

Easy to use “plug and play” device. The predefined split ratio eliminates tedious adjustments to capillary tubing. Split ratio changes are accomplished by changing the resistor set. The split ratio is determined by the ratio of fluid resistors installed in the splitter manifold. The pressure drop across a fixed splitter for post column applications is typically low, less than 500 PSI, and high for precolumn applications where the pressure is nominally 1,500 PSI. Available in models for semi-preparative and analytical inlet flow rates.



QuickSplit Binary Fixed Flow Splitter

QuickSplit™ Multiport Fixed Flow Splitter

Divides the incoming flow stream into 3 or 4 channels. The QuickSplit Multiport Flow Splitter is ideal for applications that use multiple detectors and/or a fraction collector. Split ratios can be configured to be identical in each channel or custom configured to accommodate specific flow rates at each channel. Split ratios at each channel can be changed at any time by simply replacing the fluid resistor. The low internal dead volume prevents excessive dispersion. The replaceable inlet filter prevents clogging. Available in models for semi-preparative and analytical inlet flow rates.



QuickSplit Multiport Fixed Flow Splitter

Post-Column Fixed Flow Splitters

Post-column splitting is fairly straight forward. Like pre-column flow splitting, any significant additional pressure (resistance) downstream from the splitter may affect the split ratio. Post-column devices also contribute to chromatographic dispersion so care must be given to connecting tubing and fittings, especially at low flow rates. The pressure drop specification for both analytical and semi-preparative fixed splitters is 500 PSI with water at a flow rate of 1.0 mL/min. and 20.0 mL/min. respectively. Splitters are shipped complete with fluid resistors installed. **Higher inlet flow rates may result in a larger pressure drop across the flow splitter. To assure a maximum pressure drop of 500 PSI across the splitter, please specify the inlet flow when the splitter is ordered.**

Custom Split Ratios

Split ratios and resistor cartridges other than those listed below can be ordered from ASI to custom configure the QuickSplit Fixed Flow Splitter. Please contact technical support at 800-344-4340 for additional information about custom splitters. We will gladly assist you in determining the best splitter configuration for your application.

QuickSplit™ Binary Fixed Flow Splitters

Analytical Splitters - Binary

Analytical range, 0.1 mL/min. to 5 mL/min. input flow

These splitters will produce under 500 PSI backpressure with water at 1.0 mL/min. The backpressure will decrease in direct proportion to a decrease in flow rate. Flow rates higher than 1.0 mL/min. can be used, but may result in a higher pressure drop across the splitter.

Description		ASI Part Number
Analytical Fixed Flow Splitter, Post-Column	Split Ratio = 2,000:1	620-PO10-03*
Analytical Fixed Flow Splitter, Post-Column	Split Ratio = 1,000:1	620-PO10-04*
Analytical Fixed Flow Splitter, Post-Column	Split Ratio = 500:1	620-PO10-05*
Analytical Fixed Flow Splitter, Post-Column	Split Ratio = 200:1	620-PO10-06*
Analytical Fixed Flow Splitter, Post-Column	Split Ratio = 100:1	620-PO10-07*
Analytical Fixed Flow Splitter, Post-Column	Split Ratio = 50:1	620-PO10-08*
Analytical Fixed Flow Splitter, Post-Column	Split Ratio = 20:1	620-PO10-09*
Analytical Fixed Flow Splitter, Post-Column	Split Ratio = 10:1	620-PO10-10*
Analytical Fixed Flow Splitter, Post-Column	Split Ratio = 5:1	620-PO10-11*
Analytical Fixed Flow Splitter, Post-Column	Split Ratio = 3:1	620-PO10-12*
Analytical Fixed Flow Splitter, Post-Column	Split Ratio = 1:1	620-PO10-13*
Analytical Fixed Flow Splitter, Post-Column	Split Ratio = Custom	620-PO10-CS*

* Does not come with mounting bracket, please see Page 24 for mounting bracket order information.

QuickSplit Fixed Flow Splitters

Analytical Replacement Resistor Sets - Binary

Description		ASI Part Number
Analytical Fixed Flow Splitter Resistor Set, Post-Column	Split Ratio = 2,000:1	620-1110-03
Analytical Fixed Flow Splitter Resistor Set, Post-Column	Split Ratio = 1,000:1	620-1110-04
Analytical Fixed Flow Splitter Resistor Set, Post-Column	Split Ratio = 500:1	620-1110-05
Analytical Fixed Flow Splitter Resistor Set, Post-Column	Split Ratio = 200:1	620-1110-06
Analytical Fixed Flow Splitter Resistor Set, Post-Column	Split Ratio = 100:1	620-1110-07
Analytical Fixed Flow Splitter Resistor Set, Post-Column	Split Ratio = 50:1	620-1110-08
Analytical Fixed Flow Splitter Resistor Set, Post-Column	Split Ratio = 20:1	620-1110-09
Analytical Fixed Flow Splitter Resistor Set, Post-Column	Split Ratio = 10:1	620-1110-10
Analytical Fixed Flow Splitter Resistor Set, Post-Column	Split Ratio = 5:1	620-1110-11
Analytical Fixed Flow Splitter Resistor Set, Post-Column	Split Ratio = 3:1	620-1110-12
Analytical Fixed Flow Splitter Resistor Set, Post-Column	Split Ratio = 1:1	620-1110-13
Analytical Fixed Flow Splitter Resistor Set, Post-Column	Split Ratio = Custom	620-1110-CS

Semi-Preparative Splitters - Binary

Semi-Prep range, 5 mL/min. to 40 mL/min. input flow

These splitters will produce under 500 PSI backpressure with water at 20.0 mL/min. The backpressure will decrease in direct proportion to a decrease in flow rate. Flow rates higher than 20.0 mL/min. can be used, but may result in a higher pressure drop across the splitter. **In order to assure <500 PSI pressure drop across the splitter, please specify the inlet flow when you order.**

Description		ASI Part Number
Semi-Preparative Fixed Flow Splitter, Post-Column	Split Ratio = 20,000:1	620-PO20-00*
Semi-Preparative Fixed Flow Splitter, Post-Column	Split Ratio = 10,000:1	620-PO20-01*
Semi-Preparative Fixed Flow Splitter, Post-Column	Split Ratio = 5,000:1	620-PO20-02*
Semi-Preparative Fixed Flow Splitter, Post-Column	Split Ratio = 2,000:1	620-PO20-03*
Semi-Preparative Fixed Flow Splitter, Post-Column	Split Ratio = 1,000:1	620-PO20-04*
Semi-Preparative Fixed Flow Splitter, Post-Column	Split Ratio = 500:1	620-PO20-05*
Semi-Preparative Fixed Flow Splitter, Post-Column	Split Ratio = Custom	620-PO20-CS*

* Does not come with mounting bracket.

The Low Flow Resistor Cartridge can be disassembled for cleaning in the event of clogging. To change split ratio, please contact technical support at 800-344-4340.

Post-Column Fixed Flow Splitters continued

Semi-Preparative Replacement Resistor Cartridges - Binary

Description		ASI Part Number
Semi-Preparative Fixed Flow Splitter High Flow Resistor Cartridge, Post-Column	Split Ratio = 20,000:1	620-1120-00H
Semi-Preparative Fixed Flow Splitter High Flow Resistor Cartridge, Post-Column	Split Ratio = 10,000:1	620-1120-01H
Semi-Preparative Fixed Flow Splitter High Flow Resistor Cartridge, Post-Column	Split Ratio = 5,000:1	620-1120-02H
Semi-Preparative Fixed Flow Splitter High Flow Resistor Cartridge, Post-Column	Split Ratio = 2,000:1	620-1120-03H
Semi-Preparative Fixed Flow Splitter High Flow Resistor Cartridge, Post-Column	Split Ratio = 1,000:1	620-1120-04H
Semi-Preparative Fixed Flow Splitter High Flow Resistor Cartridge, Post-Column	Split Ratio = 500:1	620-1120-05H
Semi-Preparative Fixed Flow Splitter High Flow Resistor Cartridge, Post-Column	Split Ratio = Custom	620-1120-CSH

QuickSplit™ Multiport Fixed Flow Splitters

Please call *ASI* for assistance in configuring your *QuickSplit* Multiport Fixed Splitter prior to ordering. **Please specify inlet flow rate and desired output flow rate in each channel when you order.**

Analytical Splitters - Multiport

Analytical range, 0.1 mL/min. to 5 mL/min. input flow

These splitters will produce under 500 PSI backpressure with water at 1.0 mL/min. The backpressure will decrease in direct proportion to a decrease in flow rate. Flow rates higher than 1.0 mL/min. can be used, but may result in higher a pressure drop across the splitter.

Description		ASI Part Number
Analytical Three Port Fixed Flow Splitter, Post-Column	Split Ratio = Custom	630-PO10-CS*
Analytical Four Port Fixed Flow Splitter, Post-Column	Split Ratio = Custom	640-PO10-CS*

* Comes with mounting bracket.

Analytical Replacement Resistor Sets* - Multiport

Description		ASI Part Number
Analytical Three Port Fixed Flow Splitter Resistor Set, Post-Column	Split Ratio = Custom	630-1110-CS
Analytical Four Port Fixed Flow Splitter Resistor Set, Post-Column	Split Ratio = Custom	640-1110-CS

***Please contact *ASI* before ordering replacement resistor sets for your *QuickSplit* Multiport Fixed Flow Splitter.**

Semi-Preparative Splitters - Multiport

Semi-Prep range, 5 mL/min. to 40 mL/min. input flow

These splitters will produce under 500 PSI backpressure with water at 20.0 mL/min. The backpressure will decrease in direct proportion to a decrease in flow rate. Flow rates higher than 20.0 mL/min can be used, but may result in a higher pressure drop across the splitter.

Description	ASI Part Number
Semi-Preparative Three Port Fixed Flow Splitter, Post-Column	Split Ratio = Custom 630-PO20-CS*
Semi-Preparative Four Port Fixed Flow Splitter, Post-Column	Split Ratio = Custom 640-PO20-CS*

* Comes with mounting bracket.

Semi-Preparative Splitters Replacement Resistor Sets* - Multiport

Description	ASI Part Number
Semi-Preparative Three Port Fixed Flow Splitter Resistor Set, Post-Column	Split Ratio = Custom 630-1120-CS
Semi-Preparative Four Port Fixed Flow Splitter Resistor Set, Post-Column	Split Ratio = Custom 640-1120-CS

***Please contact ASI before ordering replacement resistor sets for your QuickSplit Multiport Fixed Flow Splitter.**

QuickSplit™ Makeup-Flow Splitter Manifolds

The ASI QuickSplit Makeup-Flow Splitter Manifold is designed for post-column applications where a small amount of flow from an HPLC column is efficiently combined with a makeup-flow before it reaches the detector. Although there are many variations of this type of application, one of the most common involves splitting a small portion of the outlet flow from a preparative HPLC column which is then combined and diluted with a makeup-flow. The combined makeup-flow is used by a detector, typically Mass Spec. or UV, to trigger fraction collection from the remaining flow. A minimum delay time of 5 seconds (maximum inlet flow) is built into the splitter to insure proper sequencing between detection and fraction collection. Unique integral design eliminates tees and fittings within the splitter, resulting in extremely low peak dispersion. An additional splitter can be added after the manifold to allow splitting the makeup-flow stream prior to entering the detector. **Custom configuration orders must include inlet flow, split ratio, and delay time. In order to assure <500 PSI pressure drop across the splitter, please specify the inlet flow when you order.**

Makeup-Flow Splitter Manifolds

Description	ASI Part Number
Makeup-Flow Splitter Manifold Flow Range: 1 - 20 mL/min. Split Ratio = 1,000:1	620-PO90-01
Makeup-Flow Splitter Manifold Flow Range: 20 - 50 mL/min. Split Ratio = 1,000:1	620-PO90-02
Makeup-Flow Splitter Manifold Flow Range: 50 - 150 mL/min. Split Ratio = 5,000:1	620-PO90-03
Makeup-Flow Splitter Manifold Flow Range: Custom Split Ratio = Custom	620-PO90-CS

QuickSplit Fixed Flow Splitters

Makeup-Flow Splitter Manifold Replacement Resistor Cartridges

Description			ASI Part Number
Prep Flow Resistor Cartridge	Flow Range: 1 - 20 mL/min.	Split Ratio = 1,000:1	620-1190-01P
Prep Flow Resistor Cartridge	Flow Range: 20 - 50 mL/min.	Split Ratio = 1,000:1	620-1190-02P
Prep Flow Resistor Cartridge	Flow Range: 50 - 150 mL/min.	Split Ratio = 5,000:1	620-1190-03P
Prep Flow Resistor Cartridge	Flow Range: Custom	Split Ratio = Custom	620-1190-CSP

The Low Flow Resistor Cartridge can be disassembled for cleaning in the event of clogging. To change flow range or split ratio, please contact technical support at 800-344-4340.

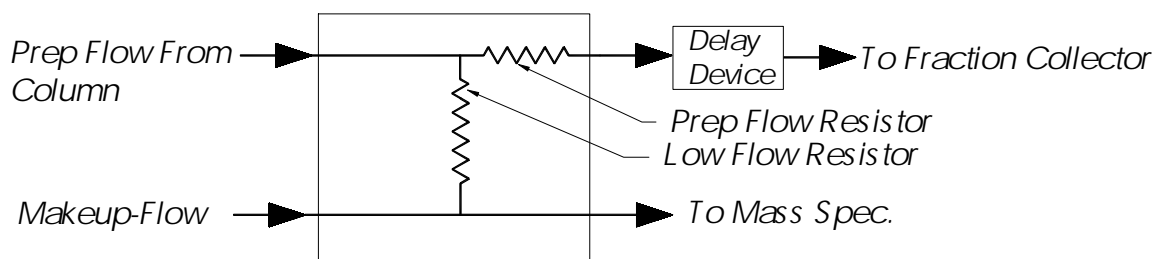

Pre-Column Fixed Flow Splitters

Pre-column splitting is used for micro, capillary, and nano HPLC applications, where the flow from the pump is split from analytical flow rates down to microliter or nanoliter flows. It is important to note that even though the split ratio created by the splitter valve will remain constant, the split ratio will change when a HPLC column is installed. This is due to the added resistance on the low flow rate channel from the HPLC column. This added resistance must be factored in to make sure the fluid resistors selected for the flow splitter provide the correct split ratio. Please contact *ASI* if you need assistance. Splitters are shipped complete with fluid resistors installed.

When ordering a pre-column flow splitter please provide *ASI* with the column flow rate and back pressure. If the inlet flow rate or column pressure specification is not provided, *ASI* will configure pre-column flow splitters assuming a 0.5 mL/min. splitter inlet flow rate and a pressure drop across the column of 1,500 PSI. Adjustments to the low flow rate channel can be made by increasing or decreasing the splitter inlet flow rate.

Custom Split Ratios

Split ratios and resistor cartridges other than those listed below can be ordered from *ASI* to custom configure the *QuickSplit* Fixed Flow Splitter. Please contact technical support at 800-344-4340 for additional information about custom splitters. We will gladly assist you in determining the best splitter configuration for your application.

QuickSplit™ Binary Fixed Flow Splitters

Analytical Splitters - Binary

Analytical range, 0.1 mL/min. to 0.5 mL/min. input flow

The pressure drop across a pre-column flow splitter will generally be between 1,000 PSI to 3,500 PSI. The exact pressure drop will depend on how the splitter is configured.

Description		ASI Part Number
Analytical Fixed Flow Splitter, Pre-Column	Split Ratio = 2,000:1	620-PR10-03*
Analytical Fixed Flow Splitter, Pre-Column	Split Ratio = 1,000:1	620-PR10-04*
Analytical Fixed Flow Splitter, Pre-Column	Split Ratio = 500:1	620-PR10-05*
Analytical Fixed Flow Splitter, Pre-Column	Split Ratio = 200:1	620-PR10-06*
Analytical Fixed Flow Splitter, Pre-Column	Split Ratio = 100:1	620-PR10-07*
Analytical Fixed Flow Splitter, Pre-Column	Split Ratio = 50:1	620-PR10-08*
Analytical Fixed Flow Splitter, Pre-Column	Split Ratio = 20:1	620-PR10-09*
Analytical Fixed Flow Splitter, Pre-Column	Split Ratio = 10:1	620-PR10-10*
Analytical Fixed Flow Splitter, Pre-Column	Split Ratio = Custom	620-PR10-CS*

* Does not come with mounting bracket, please see Page 24 for mounting bracket order information.

Analytical Replacement Resistor Sets - Binary

Description		ASI Part Number
Analytical Fixed Flow Splitter Resistor Set, Pre-Column	Split Ratio = 2,000:1	620-PR00-03
Analytical Fixed Flow Splitter Resistor Set, Pre-Column	Split Ratio = 1,000:1	620-PR00-04
Analytical Fixed Flow Splitter Resistor Set, Pre-Column	Split Ratio = 500:1	620-PR00-05
Analytical Fixed Flow Splitter Resistor Set, Pre-Column	Split Ratio = 200:1	620-PR00-06
Analytical Fixed Flow Splitter Resistor Set, Pre-Column	Split Ratio = 100:1	620-PR00-07
Analytical Fixed Flow Splitter Resistor Set, Pre-Column	Split Ratio = 50:1	620-PR00-08
Analytical Fixed Flow Splitter Resistor Set, Pre-Column	Split Ratio = 20:1	620-PR00-09
Analytical Fixed Flow Splitter Resistor Set, Pre-Column	Split Ratio = 10:1	620-PR00-10
Analytical Fixed Flow Splitter Resistor Set, Pre-Column	Split Ratio = Custom	620-PR00-CS

QuickSplit Fixed Flow Splitters

Effect of Gradient on Flow Rate Stability

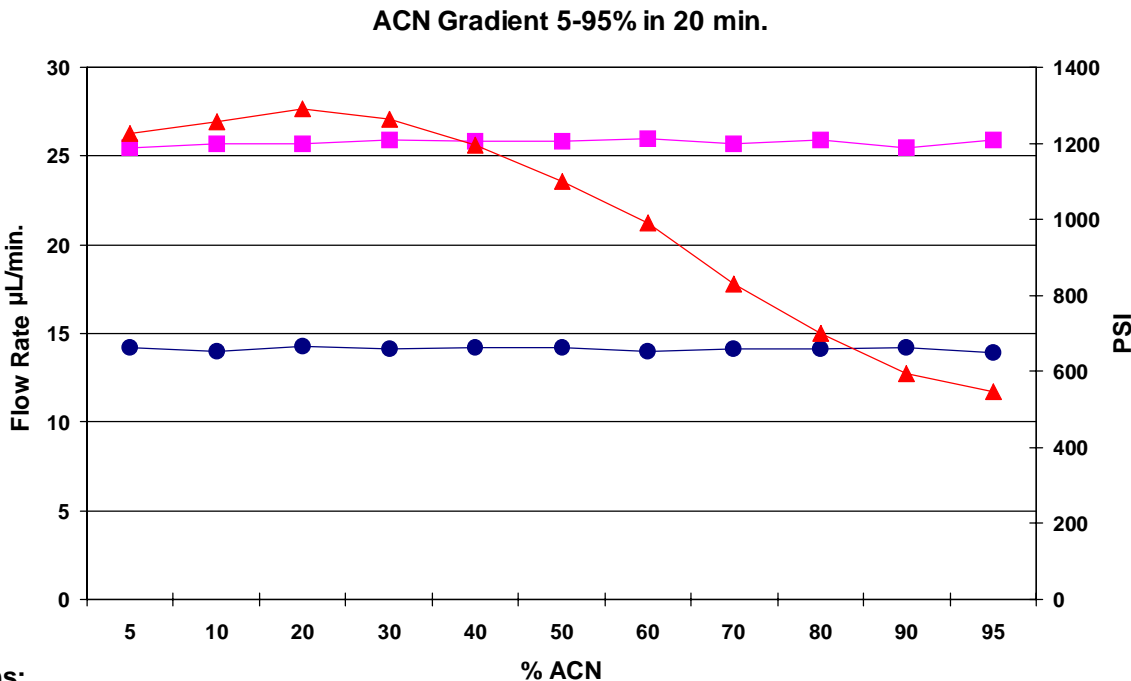

Conditions:

Splitter 620-PO10-CS

Split Ratio 15:1

Inlet Flow 400µL/min.



Effect of Viscosity on Split Ratio

Split Ratio vs %IPA

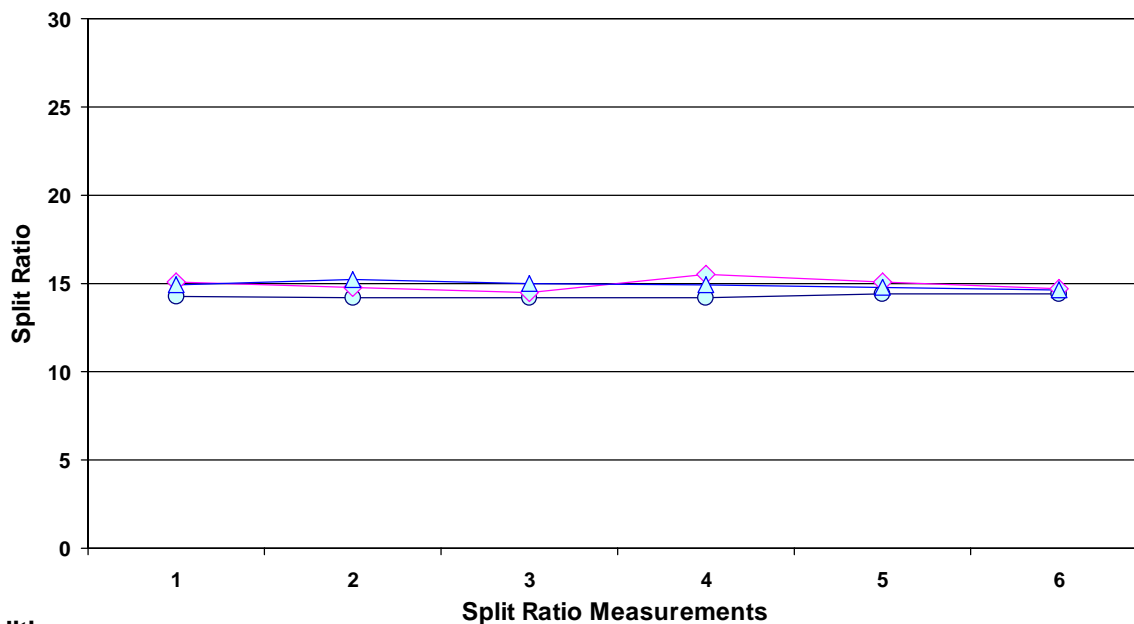

Conditions:

Splitter 620-PO10-CS

Split Ratio 15:1

Inlet Flow 400µL/min.

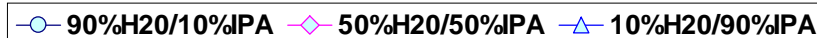

QuickSplit™ Adjustable Flow Splitter

Unlike conventional splitters that use long lengths of capillary tubing, the *ASI QuickSplit* Adjustable Flow Splitter uses fluid resistors to achieve a wide range of split ratios. The flow path of the *QuickSplit* Adjustable Flow Splitter contains two fluid resistors that form a parallel flow path. The low flow rate stream passes through a fixed resistor cartridge, while the high flow rate stream passes through an adjustable fluid resistor (metering valve). The ratio of these two resistors creates the split flow ratio. The fixed fluid resistor is analogous to a resistor used in an electrical circuit. The compact fluid resistor elements are designed as cartridges for easy replacement with resistance values (L2) rated in PSI/mL/min. Because of the extremely low internal volume of the fluid resistors, the solvent composition in both resistors at any instant in time is the same, and therefore viscosity changes associated with gradient runs do not impact the split ratio.

Due to the rugged design, the split ratio repeatability is $\pm 1\%$ of setting, and unlike alternative splitter valves or tees, will not be affected by actions that effect input flow such as turning the pump off and on, or pressure spikes. Because the *QuickSplit* Adjustable Flow Splitter incorporates a metering valve, split ratios can be changed frequently with flow changes that are stable and reproducible. The *QuickSplit* Adjustable Flow Splitter will create split ratios that are not affected by changes in solvent viscosity or pressure and provides direct real time control over split ratio optimization.

To understand how the *QuickSplit* Adjustable Flow Splitter works it helps to look at a diagram, figure 2, of the fluid resistors in relation to the flow paths and how a split ratio is calculated.

Figure 2. Schematic flow diagram of the *QuickSplit* Adjustable Flow Splitter

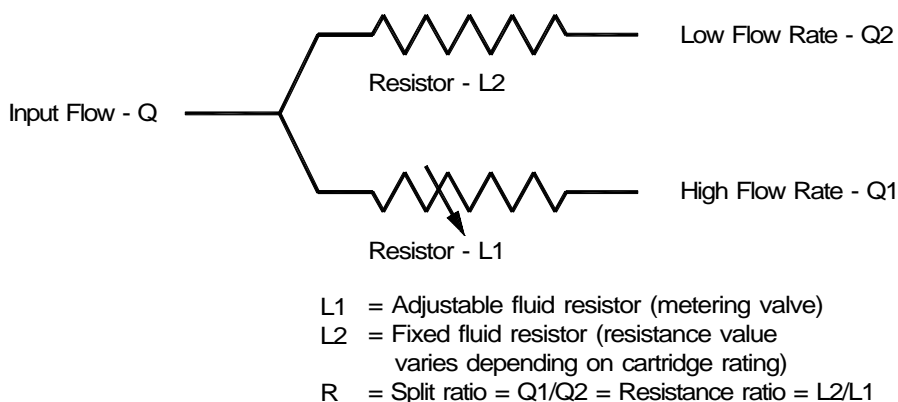

Since the flow rate is indirectly proportional to resistance, changing the resistance in either flow path results in a change to the split ratio. Changing resistance is accomplished by adjusting the metering valve on the high flow rate channel or exchanging the fixed fluid resistor cartridge in the low flow rate channel with a resistor cartridge which has a different resistance rating. Adjusting the metering valve is analogous to changing the capillary tubing length or diameter on conventional tee type flow splitters. The *QuickSplit* Adjustable Flow Splitter has a convenient mounting bracket and hand adjustment knob to control the split ratio. The split ratio is adjusted by turning the adjustment knob. Split ratios are increased by turning the adjustment knob clockwise, and decreased by turning the knob counter-clockwise. Split ratios are not affected by changes in solvent viscosities or pressure, which makes this product suitable for gradient applications as well as isocratic. The *QuickSplit* Adjustable Flow Splitter is shipped configured for either post-column or pre-column applications.

QuickSplit Adjustable Flow Splitters

QuickSplit™ Adjustable Flow Splitter

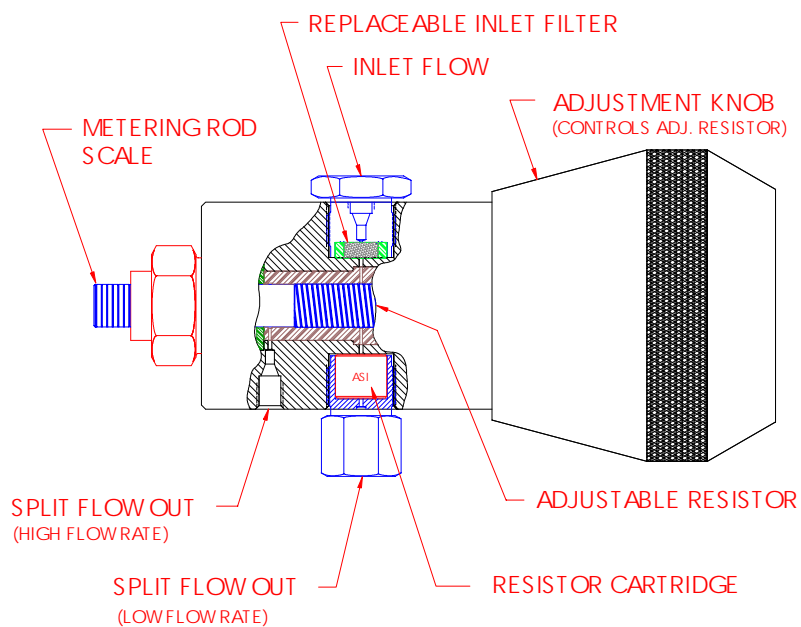

QuickSplit Adjustable Flow Splitter

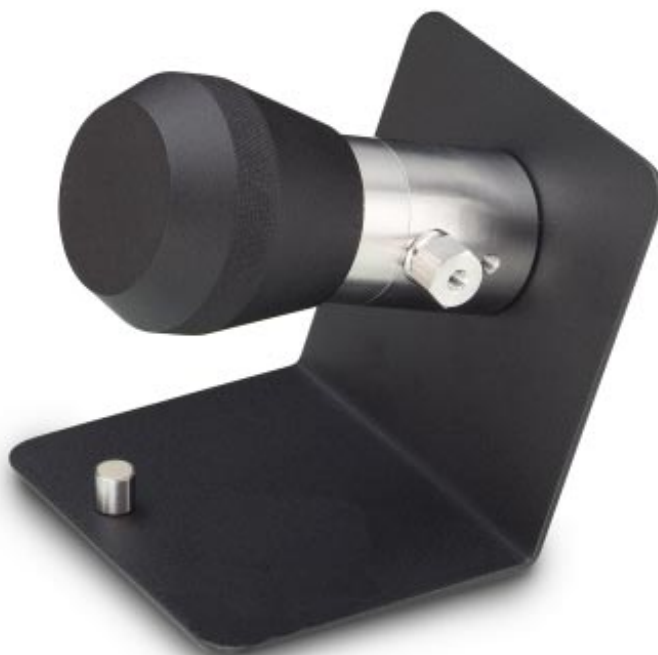

QuickSplit Adjustable Flow Splitter

Post-Column Adjustable Flow Splitters

Post-column splitting is fairly straight forward. Like pre-column flow splitting, any significant additional pressure (resistance) down stream from the splitter may affect the split ratio. Post-column devices also contribute to chromatographic dispersion so care must be given to connecting tubing and fittings, especially at low flow rates.

Use the back pressure vs split ratio chart on *page 22 and 23* to select a *QuickSplit* Adjustable Flow Splitter that will provide the desired split ratio range and back pressure. These charts correspond to several flow rates and solvent systems. The back pressure is directly proportional to flow rate and viscosity. The back pressure estimates on these charts only apply to post-column applications. Splitters are shipped complete with the resistor cartridge installed.

To assure optimum pressure drop across the splitter, please specify the inlet flow when the splitter is ordered.

Custom Split Ratios

Split ratios and resistor cartridges other than those listed below can be ordered from *ASI* to custom configure the *QuickSplit* Adjustable Flow Splitter. Please contact technical support at 800-344-4340 for additional information about custom splitters. We will gladly assist you in determining the best splitter configuration for your application.

QuickSplit™ Adjustable Flow Splitters

Analytical Splitters

Analytical range, 0.1 mL/min. to 5 mL/min. input flow

Description	Split Ratio Range	ASI Part Number
Analytical Adjustable Flow Splitter, Post-Column	50:1 to 1,000:1	600-PO10-01
Analytical Adjustable Flow Splitter, Post-Column	15:1 to 250:1	600-PO10-03
Analytical Adjustable Flow Splitter, Post-Column	5:1 to 100:1	600-PO10-04
Analytical Adjustable Flow Splitter, Post-Column	1:1 to 20:1	600-PO10-06

Analytical Replacement Resistor Cartridges

Description	Split Ratio Range	ASI Part Number
Analytical Adjustable Flow Splitter Resistor Cartridge, Post-Column	50:1 to 1,000:1	600-1110-01
Analytical Adjustable Flow Splitter Resistor Cartridge, Post-Column	15:1 to 250:1	600-1110-03
Analytical Adjustable Flow Splitter Resistor Cartridge, Post-Column	5:1 to 100:1	600-1110-04
Analytical Adjustable Flow Splitter Resistor Cartridge, Post-Column	1:1 to 20:1	600-1110-06

Post-Column Adjustable Flow Splitters continued

Semi-Preparative Splitters

Semi-Prep range, 5 mL/min. to 40 mL/min. input flow

Description	Split Ratio Range	ASI Part Number
Semi-Preparative Adjustable Flow Splitter, Post-Column	1,000:1 to 20,000:1	600-PO20-00
Semi-Preparative Adjustable Flow Splitter, Post-Column	100:1 to 2,000:1	600-PO20-01
Semi-Preparative Adjustable Flow Splitter, Post-Column	15:1 to 300:1	600-PO20-02
Semi-Preparative Adjustable Flow Splitter, Post-Column	1:1 to 20:1	600-PO20-03

Semi-Preparative Replacement Resistor Cartridges

Description	Split Ratio Range	ASI Part Number
Semi-Preparative Adjustable Flow Splitter Resistor Cartridge, Post-Column	1,000:1 to 20,000:1	600-1120-00
Semi-Preparative Adjustable Flow Splitter Resistor Cartridge, Post-Column	100:1 to 2,000:1	600-1120-01
Semi-Preparative Adjustable Flow Splitter Resistor Cartridge, Post-Column	15:1 to 300:1	600-1120-02
Semi-Preparative Adjustable Flow Splitter Resistor Cartridge, Post-Column	1:1 to 20:1	600-1120-03

Preparative Splitters

Prep range, 40 mL/min. to 200 mL/min. input flow

Description	Split Ratio Range	ASI Part Number
Preparative Adjustable Flow Splitter, Post-Column Flow Range: 40 - 125 mL/min.	Custom	600-PO30-CS
Preparative Adjustable Flow Splitter, Post-Column Flow Range: 75 - 200 mL/min.	Custom	600-PO40-CS

Preparative Replacement Resistor Cartridges

Description	Split Ratio Range	ASI Part Number
Preparative Adjustable Flow Splitter Resistor Cartridge, Post-Column, Flow Range: 40 - 125 mL/min.	Custom	600-1130-CS
Preparative Adjustable Flow Splitter Resistor Cartridge, Post-Column, Flow Range: 75 - 200 mL/min.	Custom	600-1140-CS

Pre-Column Adjustable Flow Splitters

Pre-column splitting is used for micro, capillary, and nano HPLC applications, where the flow from the pump is split from analytical flow rates down to microliter or nanoliter flows. It is important to note that even though the split ratio created by the splitter valve will remain constant, the split ratio will change when a HPLC column is installed. This is due to the added resistance on the low flow rate channel from the HPLC column. This added resistance must be factored in to make sure the fluid resistor selected for the flow splitter provides the correct split ratio. Please contact ASI if you need assistance. The charts on *page 22 and 23* only estimate the pressure drop across the splitter for post column applications and do not include the HPLC column back pressure. Splitters are shipped complete with the resistor cartridge installed.

When ordering a pre-column flow splitter, please provide ASI with the column flow rate and back pressure. If the inlet flow rate or column pressure specification is not provided, ASI will configure pre-column flow splitters assuming a 0.5 mL/min. inlet flow rate and a pressure drop across the column of 1,500 PSI.

Custom Split Ratios

Split ratios and resistor cartridges other than those listed below can be ordered from ASI to custom configure the QuickSplit Adjustable Flow Splitter. Please contact technical support at 800-344-4340 for additional information about custom splitters. We will gladly assist you in determining the best splitter configuration for your application.

QuickSplit™ Adjustable Flow Splitters

Analytical Splitters

Analytical range, 0.1 mL/min. to 1 mL/min. input flow

These splitters will produce under 3,500 PSI backpressure with water at 0.5 mL/min.

Description	Split Ratio Range	ASI Part Number
Analytical Adjustable Flow Splitter, Pre-Column	50:1 to 1,000:1	600-PR10-01
Analytical Adjustable Flow Splitter, Pre-Column	15:1 to 250:1	600-PR10-03
Analytical Adjustable Flow Splitter, Pre-Column	5:1 to 100:1	600-PR10-04
Analytical Adjustable Flow Splitter, Pre-Column	1:1 to 20:1	600-PR10-06
Analytical Adjustable Flow Splitter, Pre-Column	Custom	600-PR10-CS

Analytical Replacement Resistor Cartridges

Description	Split Ratio Range	ASI Part Number
Analytical Adjustable Flow Splitter Resistor Cartridge, Pre-Column	50:1 to 1,000:1	600-PR00-01
Analytical Adjustable Flow Splitter Resistor Cartridge, Pre-Column	15:1 to 250:1	600-PR00-03
Analytical Adjustable Flow Splitter Resistor Cartridge, Pre-Column	5:1 to 100:1	600-PR00-04
Analytical Adjustable Flow Splitter Resistor Cartridge, Pre-Column	1:1 to 20:1	600-PR00-06
Analytical Adjustable Flow Splitter Resistor Cartridge, Pre-Column	Custom	600-PR00-CS

QuickSplit Adjustable Flow Splitters

QuickSplit Adjustable Flow Splitter Selection Charts

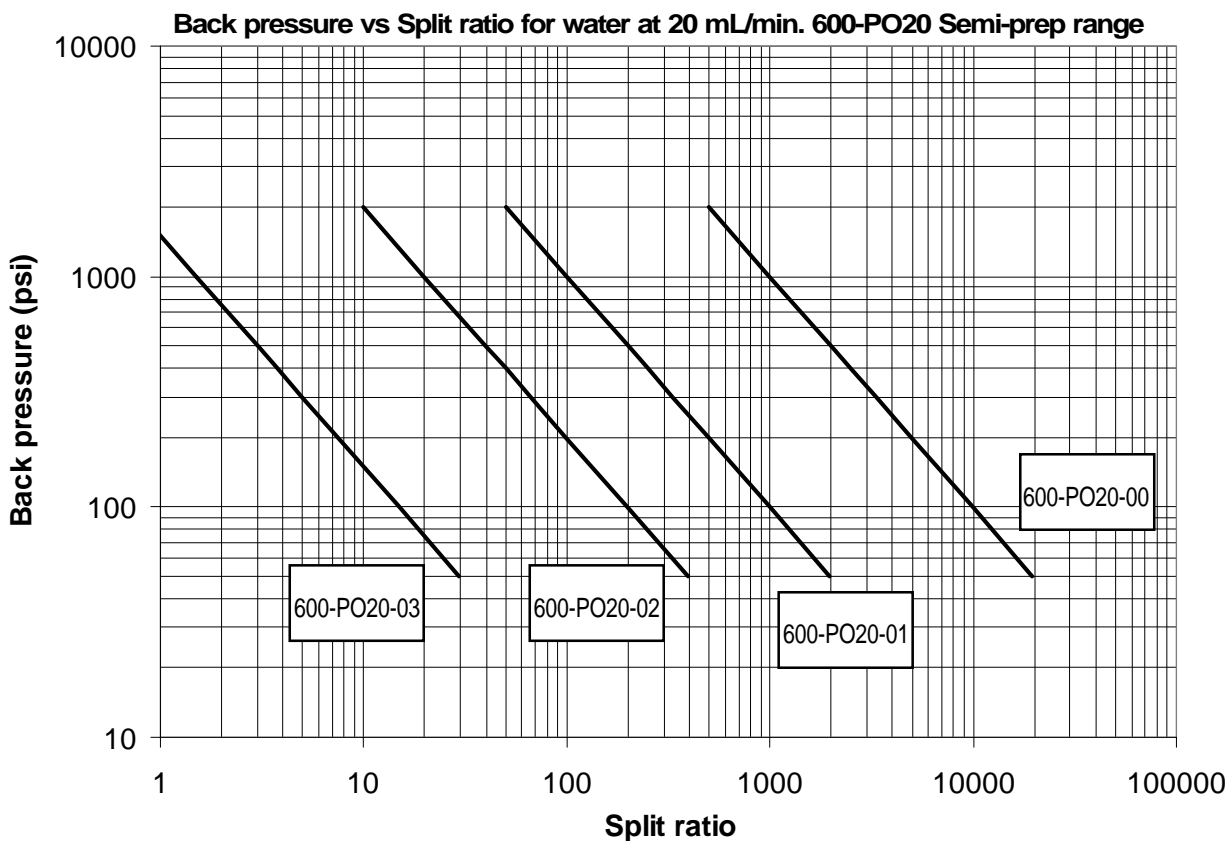
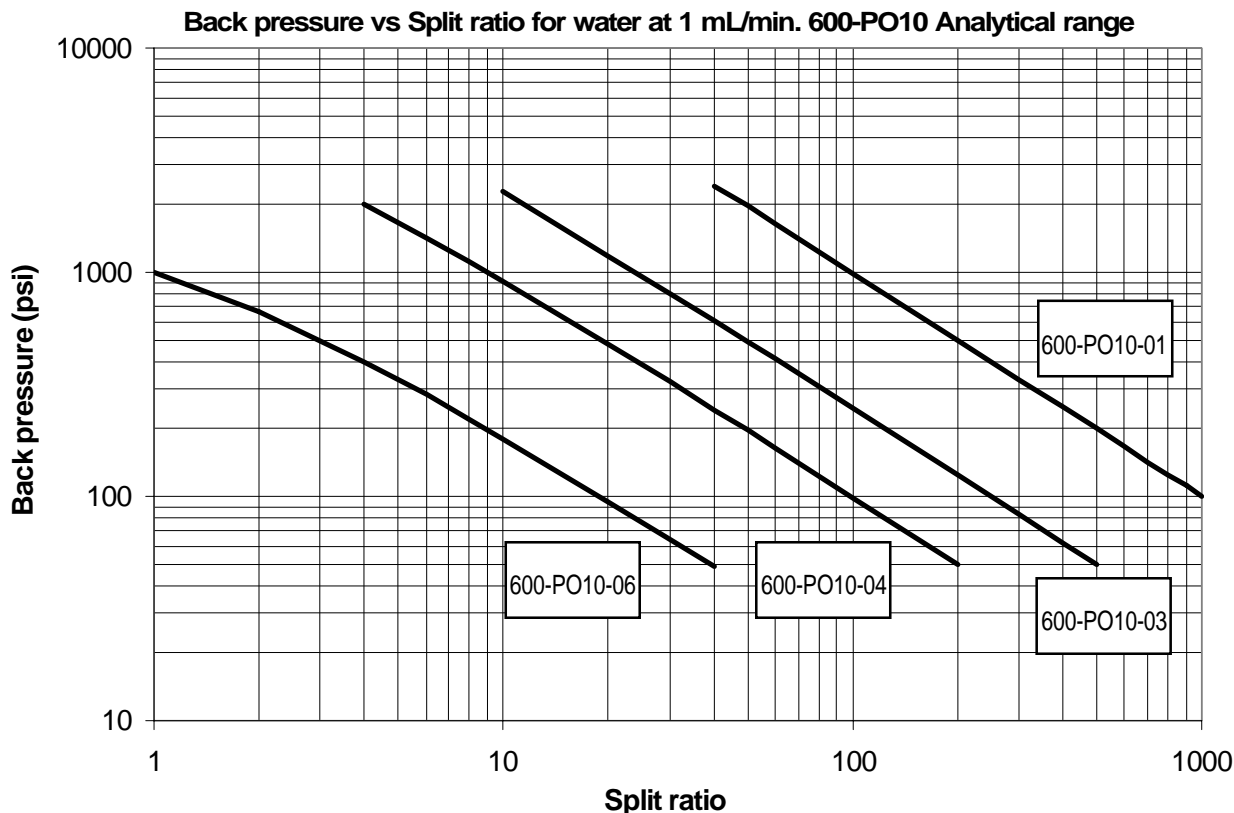

QuickSplit Adjustable Flow Splitter Selection Charts

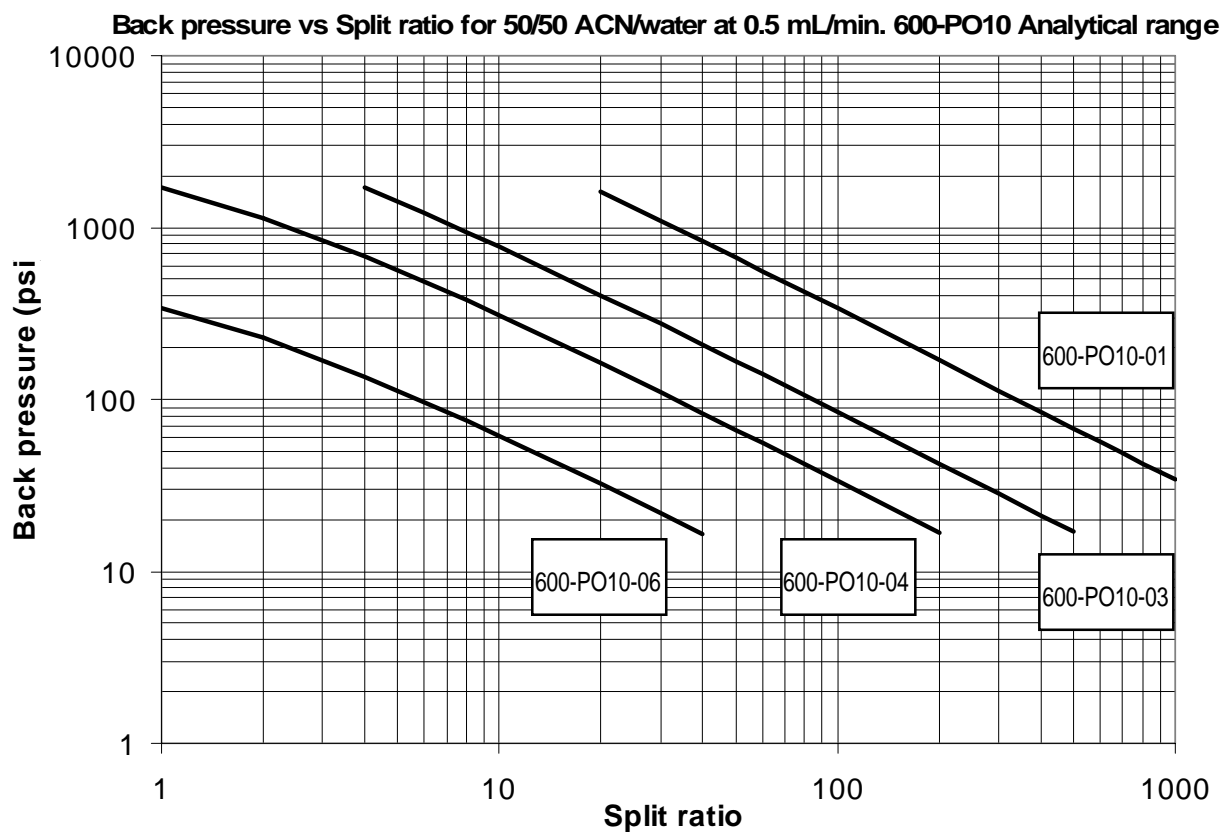
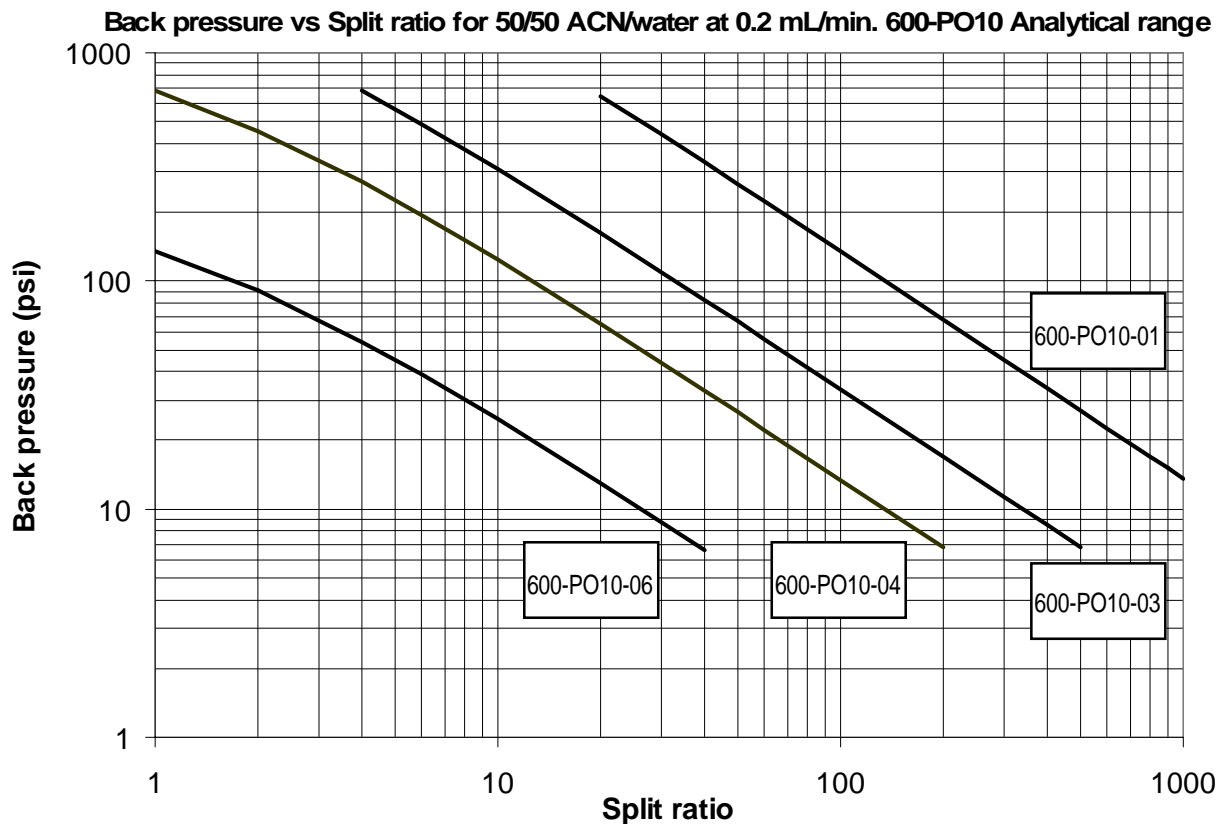

QuickSplit Flow Splitters

QuickSplit™ Flow Splitter Accessories Flow Measurement Kits*

Description	ASI Part Number
Flow Rate Range 50 nL/min. to 5 µL/min.	600-0010S*
Flow Rate Range 5 µL/min. to 25 µL/min.	600-0025S
Flow Rate Range 10 µL/min. to 100 µL/min.	600-0100S
Flow Rate Range 25 µL/min. to 500 µL/min.	600-0250S

*Kit P/N: 600-0010S interfaces to 360 µm OD fused silica tubing. All other kits interface to 1/16" OD PEEK tubing.

QuickSplit™ Fixed Flow Splitter Accessories Replacement Inlet Filters

Description	ASI Part Number
Inlet Filter, 2 micron x 0.063" dia. 5/Pack, 1 µL Volume	620-0063-2
Straight Thru Hole, No Filter 5/Pack	620-0000-0

Mounting Bracket 620

Description	ASI Part Number
Mounting Bracket for Fixed Flow Splitter	620-1000

Capillary Resistor

Description	ASI Part Number
Capillary Resistor	Custom 620-PR00-CP

QuickSplit™ Adjustable Flow Splitter Accessories Replacement Inlet Filters

Description	ASI Part Number
Inlet Filter, 2 micron x 0.063" dia. 5/Pack, 1 µL Volume	600-0063-2
Straight Thru Hole, No Filter 5/Pack	600-0000-0

Capillary Resistor

Description	ASI Part Number
Capillary Resistor	Custom 600-PR00-CP

ASI/HPLC Pumps

Isocratic Model 501



Gradient System 500G



ASI/HPLC Pump Features:

- Self-priming pump head requires no manual priming**
- Patented “Floating Pump Seal” design for extended seal wear**
- Available with analytical, semi-prep, and prep pump heads**
- Intuitive software control for isocratic and gradient systems**
- Programmable solvent compressibility compensation**
- Easy maintenance and service for all wetted parts**
- Integral prime/purge assembly for quick solvent change**

ASI HPLC Pumps

Introduction

The ASI HPLC pump is designed with the chromatographer in mind. It can be used as a reliable low cost isocratic pump or integrated into a gradient HPLC System. In either case, the pump incorporates several key features which make it truly one of a kind in the world of HPLC Pumps.

Features

Self-priming

The pump will prime itself with any solvent and at any flow rate. Turn on the pump and open the purge valve, the pump will prime itself even from a completely dry start. You will never need to use syringes to prime it.

Patented Floating Pump Seal

The seal actually floats so that it is always perfectly aligned with the piston. Our tests have proved that the average life with this new patented design is more than 5,000 hours of continuous operation at 6,000 PSI and 10 mL/min. with pure water.

Analytical, Semi-Prep, and Prep Pump Heads

The Model 501 is available in three different flow rate configurations.

Analytical Head:	0.001 mL/min. to 10 mL/min.	6,000 PSI Max
Semi-Prep Head:	0.050 mL/min. to 20 mL/min.	2,500 PSI Max
Prep Head:	0.100 mL/min. to 80 mL/min.	1,000 PSI Max

Intuitive Software Control

The control is designed with dedicated keys that allow even a novice to turn on the pump and create methods. An easy to read 4-line x 20-character LCD display allows the user to monitor several pump parameters from the same screen. The model 501 can be controlled from its own keypad or from a Model 500 gradient controller. When configured as a gradient HPLC system users can program and store up to 60 methods with 20 lines each. Methods may be linked or run independently.

Solvent Compressibility Compensation

The user may select from several different solvents from the on board library. The control automatically compensates for compressibility of the selected solvent.

Easy Maintenance

All user serviceable components are easily accessed from the front panel. Once the head assembly is removed, the pistons and seals can be replaced quickly and easily without the use of tools.

Pressure Sensor Bonded strain gage with flow through design and digital output

Prime/Purge Assembly Allows for quick and easy solvent change

Isocratic Model 501

The Model 501 is a high performance, compact solvent delivery module that has been designed to compete with the most expensive pump systems on the market in reliability and performance without the high cost. A dual piston design with solvent compressibility feedback assures virtually pulse-free and accurate solvent delivery. The Model 501 has all of the features of the Model 500, but without gradient programming capability. It may be used as an economical stand alone pump for isocratic operation, or in conjunction with a Model 500 for gradient operation.

Specifications

Accuracy:	+/- 1 % or +/- 2 microliter/min. whichever is greater
Precision:	0.25 % from 0.1 mL/min. to 10 mL/min. at 20 degrees C
Dimensions:	10-1/4" W x 14" D x 6-1/2" H
Weight:	13 lbs. (5.9 kg)
Power input:	85 to 264 VAC, 47 to 63 Hz, 60 watts

Model 500

The Model 500 has been designed to convert the Model 501 from an isocratic pump to a gradient HPLC system. Full operation and gradient control programming is achieved through the keypad on the front panel of the Model 500. The Model 500 includes a high pressure integral static mixer, connecting tubing, and all the accessories necessary to quickly convert the Model 501 to gradient operation.

Specifications

Accuracy:	+/- 1 % or +/- 2 microliter/min. whichever is greater
Precision:	0.25 % from 0.1 mL/min. to 10 mL/min. at 20 degrees C
Programming:	60 methods with 20 lines each, methods can be linked to create complex gradient programs.
Remote Start/Stop:	Controlled by external contact closure
Dimensions:	10-1/4" W x 14" D x 6-1/2" H
Weight:	14 lbs. (6.3 kg)
Power input:	85 to 264 VAC, 47 to 63 Hz, 60 watts

Model 500G

As ordered the Model 500G is a complete high pressure gradient HPLC system. The system includes one Model 501 and one Model 500. Specifications listed above.

ASI HPLC Pumps

ASI HPLC Pumps

Description	ASI Part Number
Model 501, Analytical Head	501-0000
Model 501, Semi-Prep Head	501-0020
Model 501, Prep Head	501-0040
Gradient System, Analytical Head with External Events	500G-0000E
Model 500, Analytical Head with External Events	500-0000E

Replacement Pump Head Assemblies

Description	ASI Part Number
Spring Housing with Analytical 10 mL Pump Head Assembly	A500-1001
Spring Housing with Semi-Prep 20 mL Pump Head Assembly	A500-1021
Spring Housing with Prep 80 mL Pump Head Assembly	A500-1041

Replacement Check Valves

Description	ASI Part Number
10 mL Pump Head Inlet Cartridge	A500-1050
10 mL Pump Head Inlet Housing	A500-1051
10 mL Pump Head Outlet Cartridge	A500-1055
10 mL Pump Head Outlet Housing	A500-1056
20 mL and 80 mL Pump Head Inlet Cartridge	A500-1060
20 mL and 80 mL Pump Head Inlet Housing	A500-1061
20 mL and 80 mL Pump Head Outlet Cartridge	A500-1050
20 mL and 80 mL Pump Head Outlet Housing	A500-1056

Replacement Pistons

Description	ASI Part Number
10 mL Pump Head Piston Assembly	A500-1004
20 mL Pump Head Piston Assembly	A500-1024
80 mL Pump Head Piston Assembly	A500-1044

Replacement Seals

Description	ASI Part Number
10 mL Pump Head Piston Seal Assembly 2/Pack	A500-1006-2
10 mL Pump Head Piston Seal Assembly 10/Pack	A500-1006-10
20 mL Pump Head Piston Seal Assembly 2/Pack	A500-1026-2
20 mL Pump Head Piston Seal Assembly 10/Pack	A500-1026-10
80 mL Pump Head Piston Seal Assembly 2/Pack	A500-1046-2
80 mL Pump Head Piston Seal Assembly 10/Pack	A500-1046-10

ASI Post Column Reactor



ASI Post Column Reactor Features:

- Rupture proof reactor cartridge designed for long term reliability
- Interchangeable reactor cartridges for optimizing reaction volume
- Convenient access to all PCR components
- Digital temperature controller is easy to set and read
- Modular PCR system provides maximum flexibility for system configuration
- Optional Static Mixers provide efficient mixing with minimal dispersion

ASI Post Column Reactor

Introduction

The Model 310 Post Column Reactor (PCR) Module can be used to increase detection sensitivity for variety of compounds including amino acids, proteins, carbohydrates, inorganic ions, and pesticides. The PCR consists of a temperature controller and a reactor cartridge which is designed to combine efficient mixing with low reaction volumes. This combination provides improved reaction kinetics with less peak dispersion resulting in maximum detection sensitivity.

Features

Rupture Proof Reactor Cartridge Design

Unlike conventional TFE tube reactors, the Model 310 PCR reactor will not rupture at high temperatures and pressures. Rated to 3,000 PSI at 150 °C.

Interchangeable Cartridge Reactor

Available in 0.15 mL, 0.5 mL and 1.0 mL cartridge volumes to allow for maximum flexibility for all post column applications.

Convenient Access

Pull-out oven compartment allows easy access to reactor cartridges.

Digital Temperature Control

Provides stability to 0.5 °C and thermal safety cutoff.

Specifications

Cartridge Volumes:	0.15 mL, 0.5 mL and 1.0 mL
Maximum Pressure:	3,000 PSI @ 150 °C
Temperature Control:	Solid state controller with LED display
Oven Temperature Range:	10 °C above ambient to 150 °C
Module Dimensions:	12" W x 9" D x 6" H
Wetted Materials:	Teflon®, 316 SS and PEEK
Power Requirements:	120 VAC/220 VAC, 50-60 HZ Also available 100 VAC

Carbamates EPA 531.1 Courtesy Mulan Labs, www.mulanlab.com

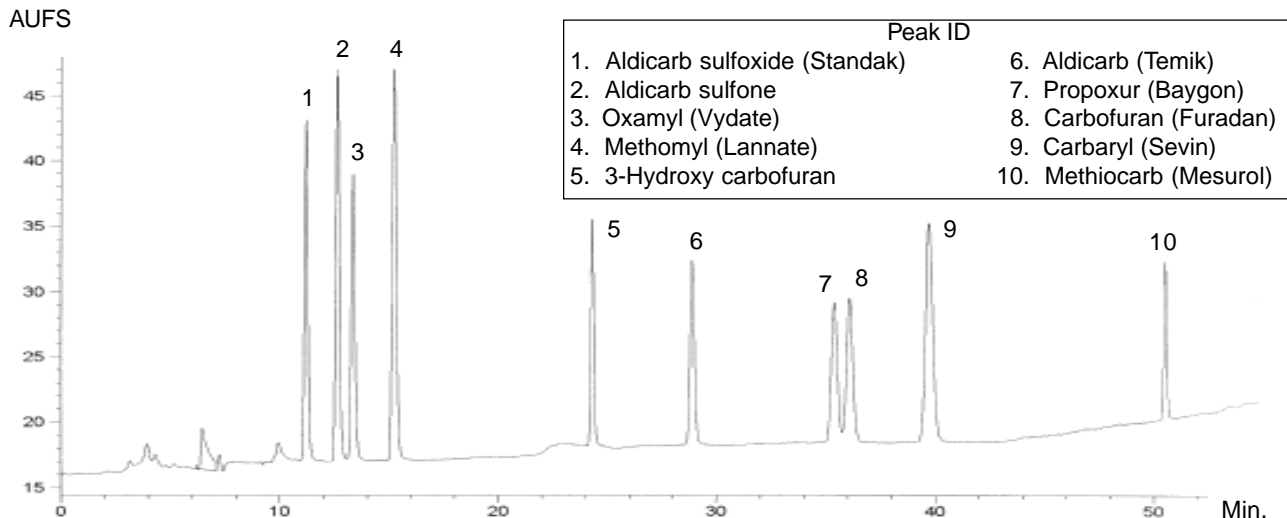

ASI Model 310 Post Column Reactor Heater Modules

Description	ASI Part Number
PCR Heater Module, 120 VAC	310-0120
PCR Heater Module, 220 VAC	310-0220
PCR Heater Module with 0.15 mL Cartridge, 120 VAC	310-0151
PCR Heater Module with 0.15 mL Cartridge, 120 VAC Biocompatible	310-0151B
PCR Heater Module with 0.15 mL Cartridge, 220 VAC	310-0152
PCR Heater Module with 0.15 mL Cartridge, 220 VAC Biocompatible	310-0152B
PCR Heater Module with 0.5 mL Cartridge, 120 VAC	310-0501
PCR Heater Module with 0.5 mL Cartridge, 120 VAC Biocompatible	310-0501B
PCR Heater Module with 0.5 mL Cartridge, 220 VAC	310-0502
PCR Heater Module with 0.5 mL Cartridge, 220 VAC Biocompatible	310-0502B
PCR Heater Module with 1.0 mL Cartridge, 120 VAC	310-1001
PCR Heater Module with 1.0 mL Cartridge, 120 VAC Biocompatible	310-1001B
PCR Heater Module with 1.0 mL Cartridge, 220 VAC	310-1002
PCR Heater Module with 1.0 mL Cartridge, 220 VAC Biocompatible	310-1002B

Reactor Cartridges

Description	ASI Part Number
Reactor Cartridge, 0.15 mL	310-0150
Reactor Cartridge, 0.15 mL Biocompatible	310-0150B
Reactor Cartridge, 0.5 mL	310-0500
Reactor Cartridge, 0.5 mL Biocompatible	310-0500B
Reactor Cartridge, 1.0 mL	310-1000
Reactor Cartridge, 1.0 mL Biocompatible	310-1000B



ASI Static Mixers

Please see page 34 for information about ASI HyperShear Static Mixers.

FlatLine™ Pulse Damper



FlatLine™ Pulse Damper Features:

- Rupture proof Pulse Damper with no diaphragm
- Flow path geometry combines clean flush out with minimal internal volume
- Custom sizes available for OEM
- Can be manufactured to include a pressure transducer and/or a prime purge valve

The *ASI FlatLine* Pulse Damper combines performance and reliability in a simple, easy to use housing. Standard 10-32 inlet and outlet ports allow quick connection into virtually any HPLC system. Solid core technology provides reliable long term operation without the down time associated with ruptured or leaking membrane dampers. Custom sizes and additional features like integral prime/purge valve available for the OEM market.

Pulse Damper

Description	ASI Part Number
Pulse Damper	590-0000

Pulse Damper Comparison

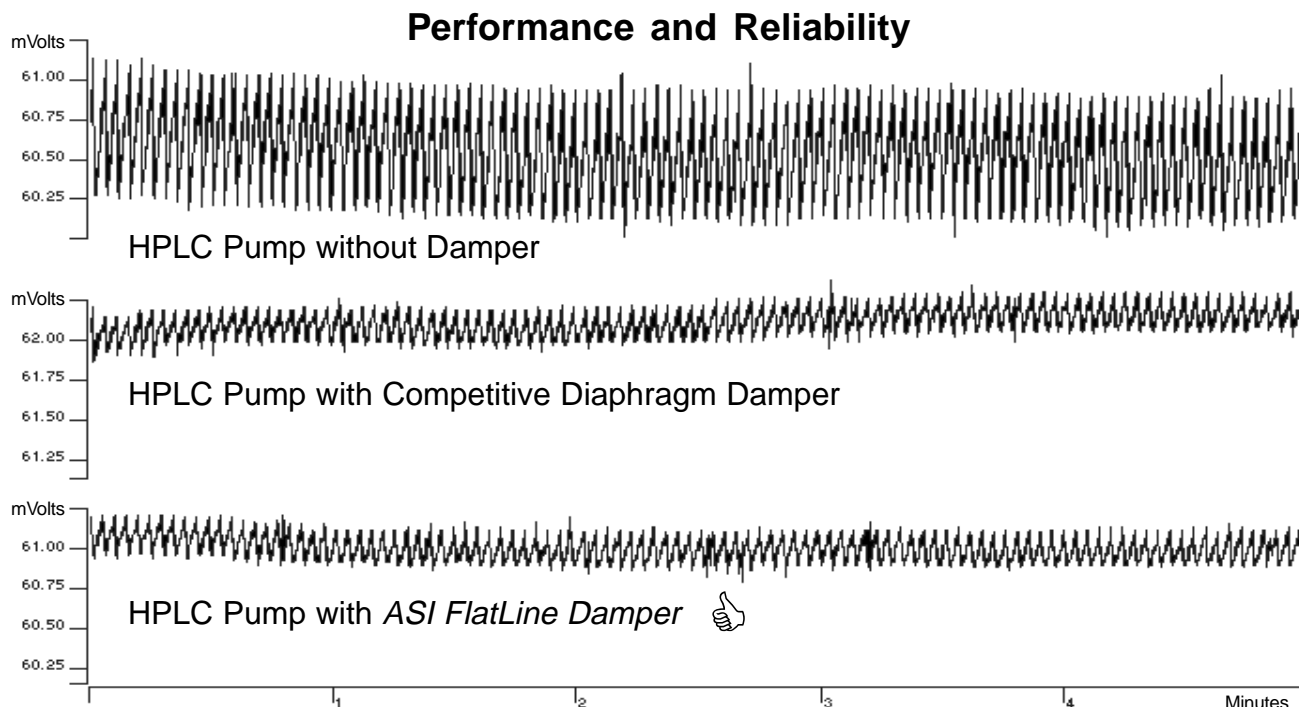

HPLC System Configuration: HPLC Pump Amplified Ext. Pressure Transducer Varian Star Data Acquisition	HPLC Conditions: MP: A = H ₂ O Flow Rate: 1.0mL/min. Isocratic Pressure: 2,300 PSI with restrictor
--	---

Solid Core Design Improves Flush Out and Dispersion

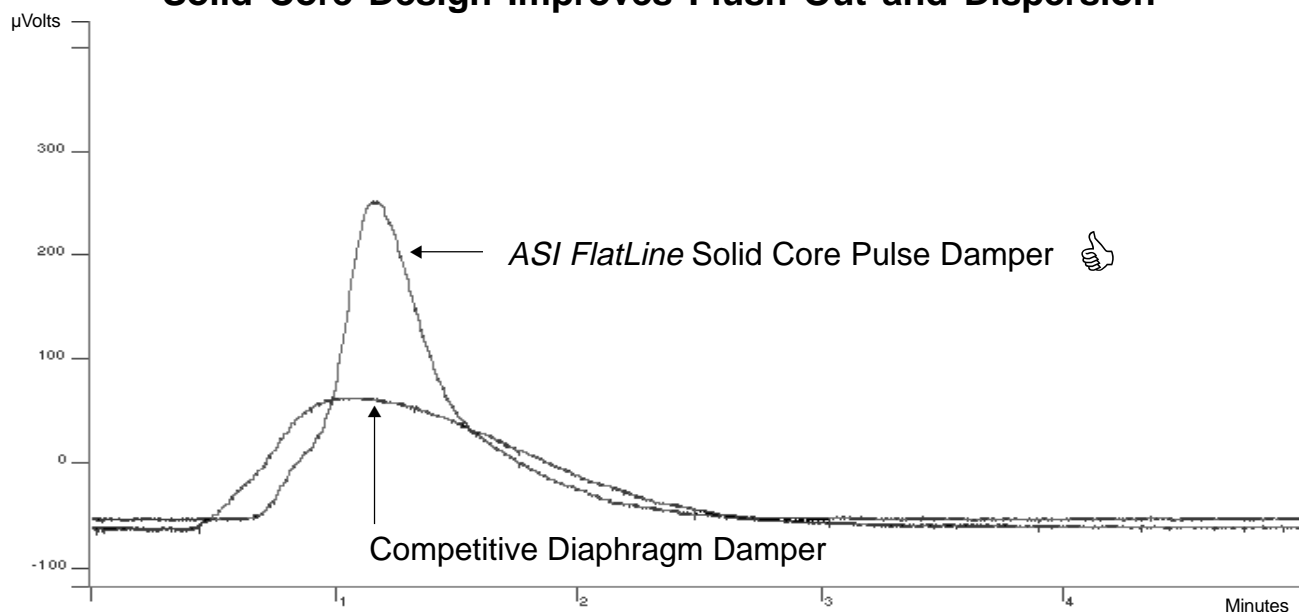

HPLC System Configuration: HPLC Pump ABI Model 785 UV/VIS @254 oncolumn Varian Star Data Acquisition	HPLC Conditions: MP: A = H ₂ O Flow Rate: 1.0mL/min. Isocratic Pressure: 2,300 PSI with restrictor Injection: 10μL Acetone
--	--

*HyperShear*TM HPLC Mixers



*HyperShear*TM HPLC Mixer Features:

- Static or Dynamic Mixers with highly efficient vortex shear mixing
- Reduce baseline noise, increase sensitivity, and improve gradient accuracy
- Mixing volume optimization is easy with interchangeable mixer cartridges
- In-line, binary, and ternary formats
- Available in stainless steel or biocompatible PEEK
- Ideal for microbore HPLC and LC/MS
- Compact design is easily integrated into any HPLC system
- Increased reaction efficiency for post column derivatization

HyperShear™ HPLC Mixers

ASI manufactures a wide range of Mixers to solve the most demanding HPLC mixing problems. ASI HyperShear HPLC Mixers incorporate a highly efficient cross-flow shearing mechanism which produces vortex shear mixing over a wide flow range. This mixing technology typically delivers between 25 % to 200 % better mixing efficiency compared to conventional stir bar or tortuous path mixers. HyperShear HPLC Mixers are available in both static and dynamic formats with volumes ranging from 0.5 µL to 1.5 mL. Most mixers are available in biocompatible PEEK.

Comparison of Baseline Noise

The baseline of this plot has been enlarged to show the noise levels associated with each mixer. Note the significant reduction in baseline noise with the ASI static mixer.

Conditions:
Gradient Program:
CH₃CN/H₂O = 50/50 --> (15 min.) 90/10
Flow Rate: 0.1mL/min.
Temp.: 40°C
Sample Size: 1µL
Sample: Solvent front
Detection Wavelength: 254nm

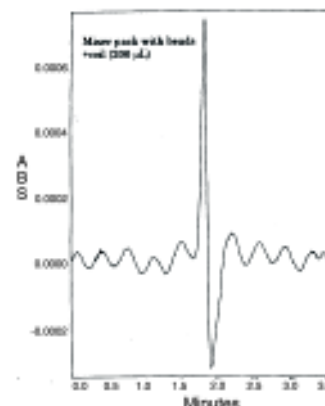
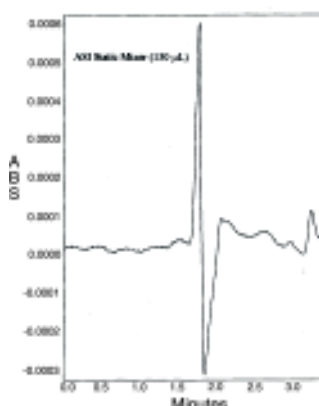

Table of Contents

HyperShear Static Mixers

Micro Flow Series, Mixing Volumes 0.5 µL to 25 µL	36
Low Flow Series, Mixing Volumes 50 µL to 250 µL	38
Analytical Flow Series, Mixing Volumes 350 µL and 500 µL	42
High Flow Series, Mixing Volumes 800 µL to 1.5 mL	44
Static Mixer Application Notes	46

HyperShear Dynamic Mixers	51
--	-----------

HyperShear Static Mixers

Micro Flow Series Stainless Steel



In-Line Complete Assembly - Cartridge and Housing

Description	ASI Part Number
In-Line Mixer Assembly SS 0.5 μ L	401-000.5
In-Line Mixer Assembly SS 1 μ L	401-0001
In-Line Mixer Assembly SS 2 μ L	401-0002
In-Line Mixer Assembly SS 5 μ L	401-0005
In-Line Mixer Assembly SS 10 μ L	401-0010
In-Line Mixer Assembly SS 25 μ L	401-0025

In-Line Assemblies

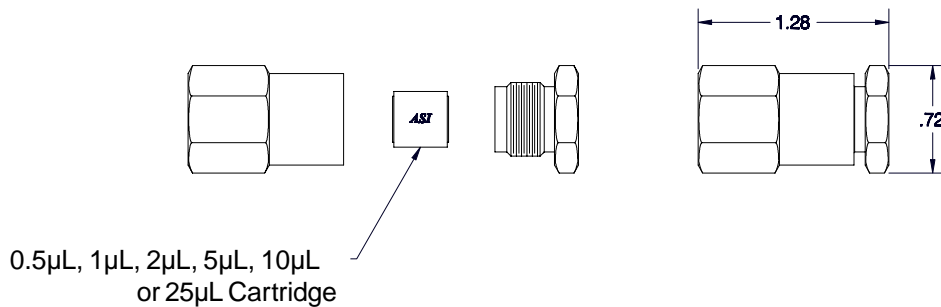

Port Size: 10-32 CPI (Standard HPLC Fittings for 1/16" Tube)

Binary Tee Complete Assembly, Stainless Steel - Cartridge and Housing

Description	ASI Part Number
Binary Tee Mixer Assembly SS 0.5 μ L	402-000.5
Binary Tee Mixer Assembly SS 1 μ L	402-0001
Binary Tee Mixer Assembly SS 2 μ L	402-0002
Binary Tee Mixer Assembly SS 5 μ L	402-0005
Binary Tee Mixer Assembly SS 10 μ L	402-0010
Binary Tee Mixer Assembly SS 25 μ L	402-0025

Ternary Tee Complete Assembly, Stainless Steel - Cartridge and Housing

Description	ASI Part Number
Ternary Tee Mixer Assembly SS 0.5 μ L	403-000.5
Ternary Tee Mixer Assembly SS 1 μ L	403-0001
Ternary Tee Mixer Assembly SS 2 μ L	403-0002
Ternary Tee Mixer Assembly SS 5 μ L	403-0005
Ternary Tee Mixer Assembly SS 10 μ L	403-0010
Ternary Tee Mixer Assembly SS 25 μ L	403-0025

Binary/Ternary Assemblies

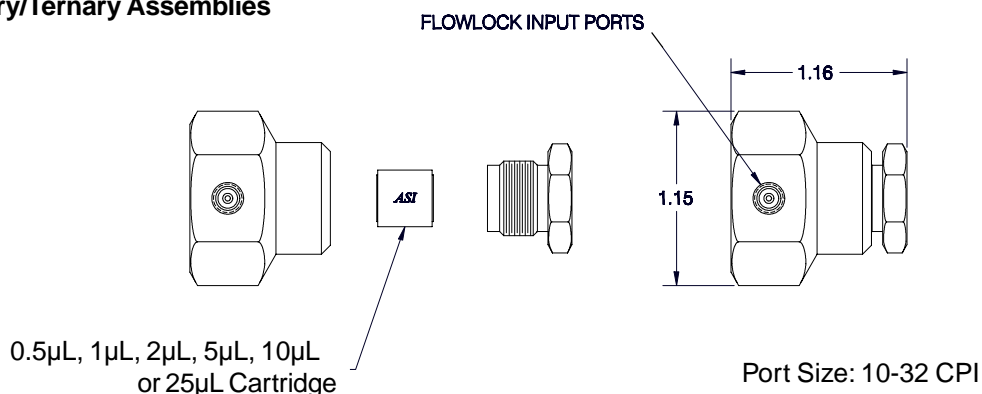

Cartridges / Housings

Description	ASI Part Number
Mixer Cartridge SS 0.5 μ L	400-000.5
Mixer Cartridge SS 1 μ L	400-0001
Mixer Cartridge SS 2 μ L	400-0002
Mixer Cartridge SS 5 μ L	400-0005
Mixer Cartridge SS 10 μ L	400-0010
Mixer Cartridge SS 25 μ L	400-0025
In-Line Micro Flow Series SS Housing	401-0000
Binary Tee Micro Flow Series SS Housing	402-0000
Ternary Tee Micro Flow Series SS Housing	403-0000

HyperShear Static Mixers

Low Flow Series Stainless Steel



In-Line Complete Assembly - Cartridge and Housing

Description	ASI Part Number
In-Line Mixer Assembly SS 50 µL	411-0050
In-Line Mixer Assembly SS 150 µL	411-0150
In-Line Mixer Assembly SS 250 µL	411-0250

In-Line Assemblies

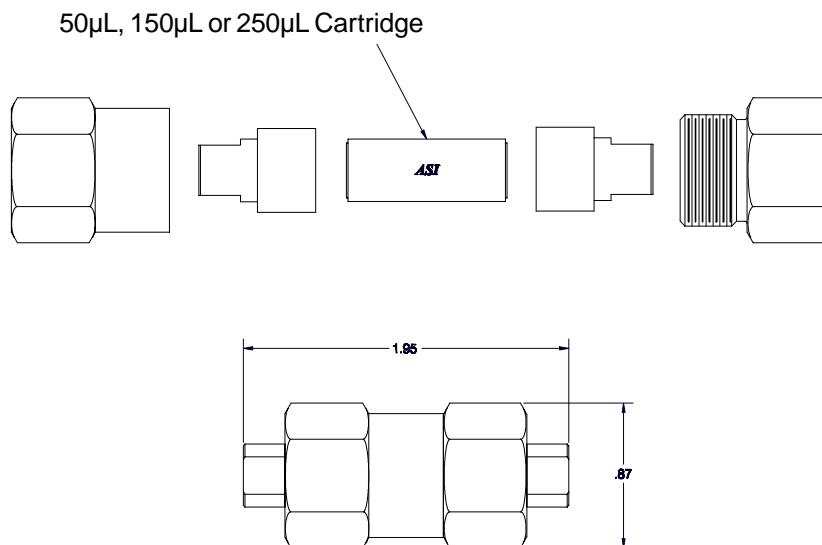

Port Size: 10-32 CPI (Standard HPLC Fittings for 1/16" Tube)

Binary Tee Complete Assembly - Cartridge and Housing

Description	ASI Part Number
Binary Tee Mixer Assembly SS 50 μ L	412-0050
Binary Tee Mixer Assembly SS 150 μ L	412-0150
Binary Tee Mixer Assembly SS 250 μ L	412-0250

Ternary Tee Complete Assembly - Cartridge and Housing

Description	ASI Part Number
Ternary Tee Mixer Assembly SS 50 μ L	413-0050
Ternary Tee Mixer Assembly SS 150 μ L	413-0150
Ternary Tee Mixer Assembly SS 250 μ L	413-0250

Binary/Ternary Assemblies

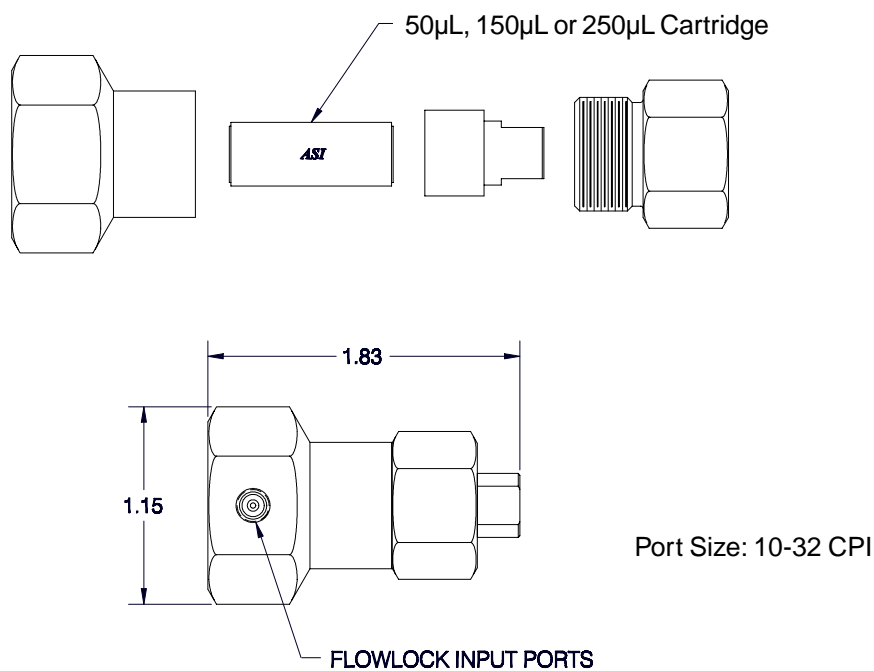

Cartridges / Housings

Description	ASI Part Number
Mixer Cartridge SS 50 μ L	410-0050
Mixer Cartridge SS 150 μ L	410-0150
Mixer Cartridge SS 250 μ L	410-0250
In-Line Low Flow Series SS Housing	411-0000
Binary Tee Low Flow Series SS Housing	412-0000
Ternary Tee Low Flow Series SS Housing	413-0000

HyperShear Static Mixers



In-Line Complete Assembly - Cartridge and Housing

Description	ASI Part Number
In-Line Mixer Assembly PEEK 50 µL	411-0050B
In-Line Mixer Assembly PEEK 150 µL	411-0150B
In-Line Mixer Assembly PEEK 250 µL	411-0250B

In-Line Assemblies

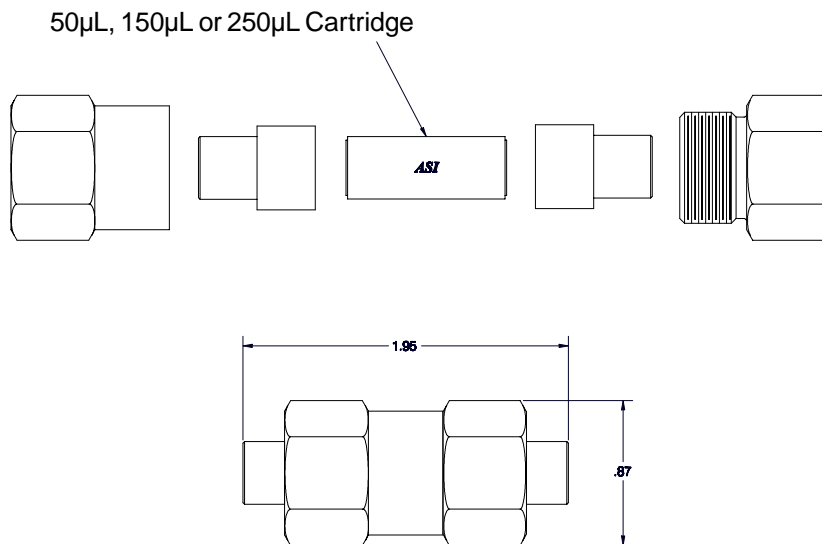

Port Size: 10-32 CPI (Standard HPLC Fittings for 1/16" Tube)

Binary Tee Complete Assembly - Cartridge and Housing

Description	ASI Part Number
Binary Tee Mixer Assembly PEEK 50 μ L	412-0050B
Binary Tee Mixer Assembly PEEK 150 μ L	412-0150B
Binary Tee Mixer Assembly PEEK 250 μ L	412-0250B

Ternary Tee Complete Assembly - Cartridge and Housing

Description	ASI Part Number
Ternary Tee Mixer Assembly PEEK 50 μ L	413-0050B
Ternary Tee Mixer Assembly PEEK 150 μ L	413-0150B
Ternary Tee Mixer Assembly PEEK 250 μ L	413-0250B

Binary/Ternary Assemblies

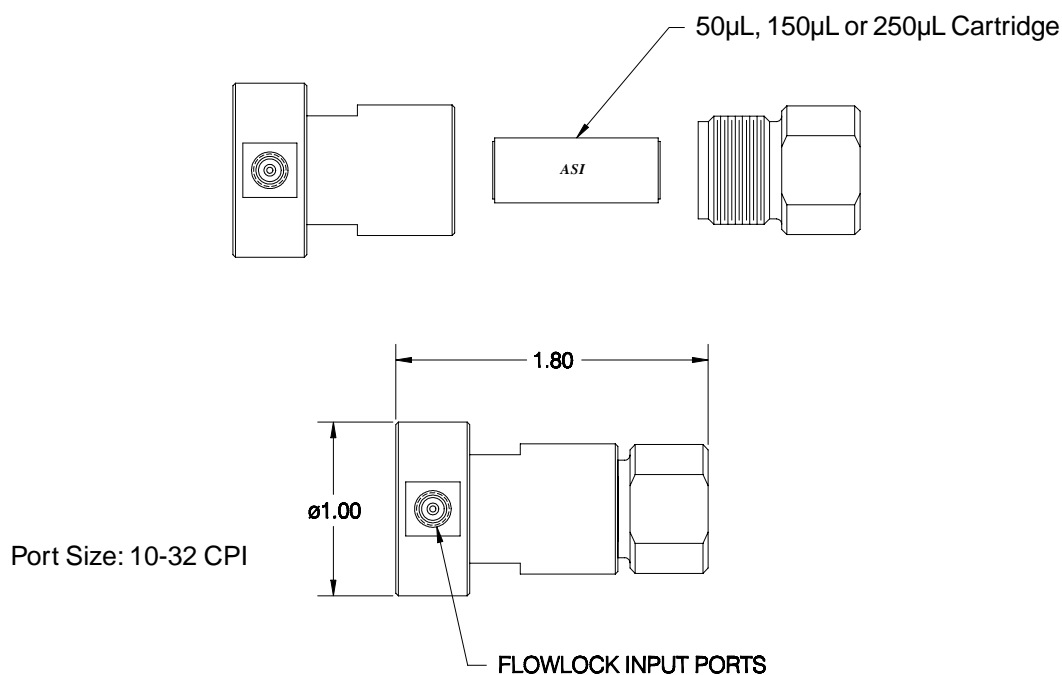

Cartridges / Housings

Description	ASI Part Number
Mixer Cartridge PEEK 50 μ L	410-0050B
Mixer Cartridge PEEK 150 μ L	410-0150B
Mixer Cartridge PEEK 250 μ L	410-0250B
In-Line Low Flow Series PEEK Housing	411-0000B
Binary Tee Low Flow Series PEEK Housing	412-0000B
Ternary Tee Low Flow Series PEEK Housing	413-0000B

HyperShear Static Mixers

Analytical Flow Series Stainless Steel, Biocompatible PEEK



In-Line Complete Assembly - Cartridge and Housing Stainless Steel

Description	ASI Part Number
In-Line Mixer Assembly SS 350 µL	421-0350
In-Line Mixer Assembly SS 500 µL	421-0500

Biocompatible PEEK

Description	ASI Part Number
In-Line Mixer Assembly PEEK 350 µL	421-0350B
In-Line Mixer Assembly PEEK 500 µL	421-0500B

In-Line Assemblies

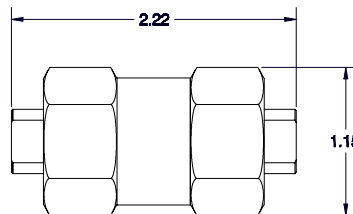
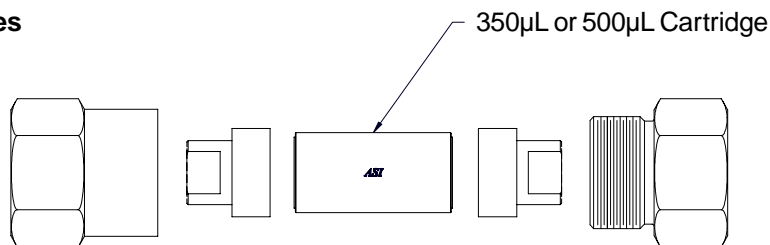

Port Size: 10-32 CPI (Standard HPLC Fittings for 1/16" Tube)

Binary Complete Assembly, Stainless Steel - Cartridge and Housing

Description	ASI Part Number
Binary Tee Mixer Assembly SS 350 μ L	422-0350
Binary Tee Mixer Assembly SS 500 μ L	422-0500

Ternary Complete Assembly, Stainless Steel - Cartridge and Housing

Description	ASI Part Number
Ternary Tee Mixer Assembly SS 350 μ L	423-0350
Ternary Tee Mixer Assembly SS 500 μ L	423-0500

Binary/Ternary Assemblies

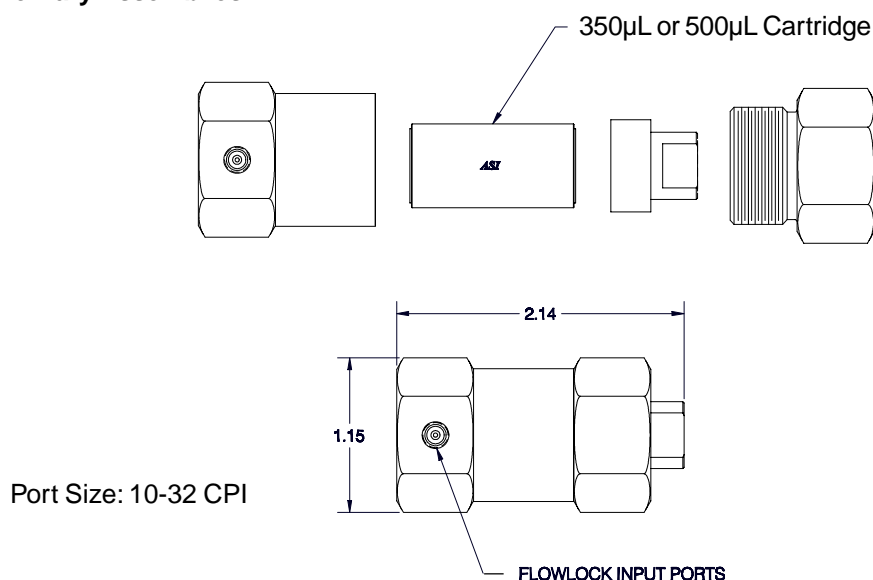

Cartridges / Housings Stainless Steel

Description	ASI Part Number
Mixer Cartridge SS 350 μ L	420-0350
Mixer Cartridge SS 500 μ L	420-0500
In-Line Analytical Flow Series SS Housing	421-0000
Binary Tee Analytical Flow Series SS Housing	422-0000
Ternary Tee Analytical Flow Series SS Housing	423-0000

Biocompatible PEEK

Description	ASI Part Number
Mixer Cartridge PEEK 350 μ L	420-0350B
Mixer Cartridge PEEK 500 μ L	420-0500B
In-Line Analytical Flow Series PEEK Housing	421-0000B

HyperShear Static Mixers



In-Line Complete Assembly - Cartridge and Housing Stainless Steel

Description	ASI Part Number
In-Line Mixer Assembly SS 800 μ L	431-0800
In-Line Mixer Assembly SS 1.0 mL	431-1000
In-Line Mixer Assembly SS 1.5 mL	431-1500

Biocompatible PEEK

Description	ASI Part Number
In-Line Mixer Assembly PEEK 800 μ L	431-0800B
In-Line Mixer Assembly PEEK 1.0 mL	431-1000B
In-Line Mixer Assembly PEEK 1.5 mL	431-1500B

In-Line Assemblies

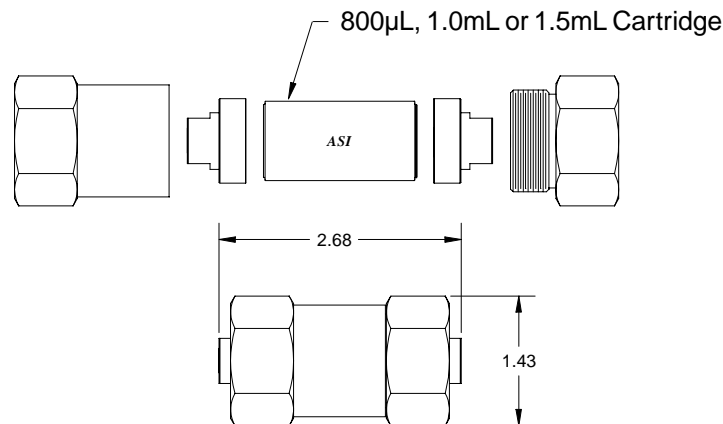

Port Size: 10-32 CPI (Standard HPLC Fittings for 1/16" Tube)

Binary Complete Assembly, Stainless Steel - Cartridge and Housing

Description	ASI Part Number
Binary Tee Mixer Assembly SS 800 μ L	432-0800
Binary Tee Mixer Assembly SS 1.0 mL	432-1000
Binary Tee Mixer Assembly SS 1.5 mL	432-1500

Ternary Complete Assembly, Stainless Steel - Cartridge and Housing

Description	ASI Part Number
Ternary Tee Mixer Assembly SS 800 μ L	433-0800
Ternary Tee Mixer Assembly SS 1.0 mL	433-1000
Ternary Tee Mixer Assembly SS 1.5 mL	433-1500

Binary/Ternary Assemblies

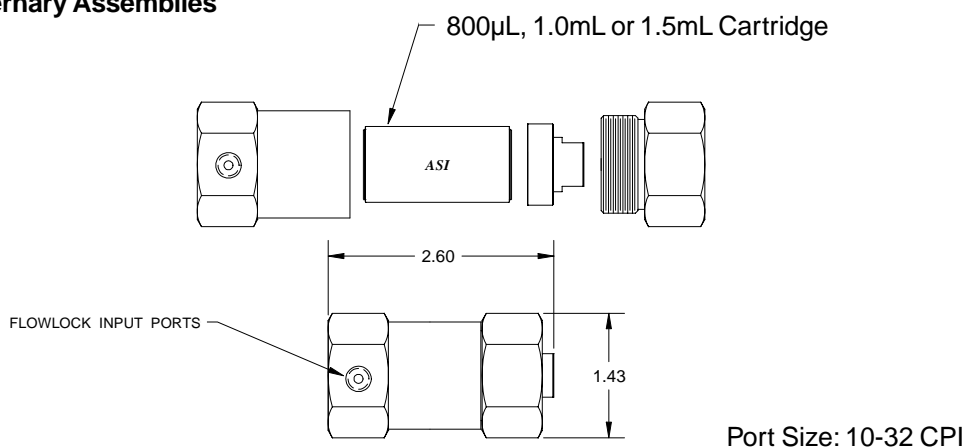

Cartridges / Housings Stainless Steel

Description	ASI Part Number
Mixer Cartridge SS 800 μ L	430-0800
Mixer Cartridge SS 1.0 mL	430-1000
Mixer Cartridge SS 1.5 mL	430-1500
In-Line High Flow Series SS Housing	431-0000
Binary Tee High Flow Series SS Housing	432-0000
Ternary Tee High Flow Series SS Housing	433-0000

Biocompatible PEEK

Description	ASI Part Number
Mixer Cartridge PEEK 800 μ L	430-0800B
Mixer Cartridge PEEK 1.0 mL	430-1000B
Mixer Cartridge PEEK 1.5 mL	430-1500B
In-Line High Flow Series PEEK Housing	431-0000B

Static Mixer Application Notes

Selecting the Right Size Mixer Cartridge

ASI offers static mixers with volumes that range from 0.5 microliters to 1,500 microliters. Choosing the right size mixer is a trade off between delay volume, mixing noise, and step gradient definition and repeatability. **Please refer to the Charts on pages 48 and 49 for more information on gradient accuracy as a function of flow rate and mixing volume.**

The following observations will provide some guidelines to help choose the right size mixer.

- For any given flow rate, the more the mixing volume the better the mixing, and the lower the baseline noise.
- The smaller the mixing volume, the better the definition and sharpness of linear gradients.
- Multi-pump high pressure gradient systems typically require far less mixing volume than low pressure single pump gradient systems when running linear gradients.
- A 150 μ L in-line static mixer can be added after a dynamic or static onboard mixer to further reduce mixing noise.

Multi-pump High Pressure Gradient Systems

Linear Gradients

If a larger mixing volume can be tolerated for a particular flow rate, the larger the volume will lower the mixing noise. The upper limits to mixing volume will be the maximum delay time that can be tolerated, and possible distortion (tailing) of the gradient at the beginning and end of the gradient. The lower limit will be defined by the amount of mixing noise that can be tolerated.

Please refer to table 1 (page 47) for specific recommendations.

Binary or Ternary – Steady State Composition

Always select the largest volume that will still provide an acceptable delay volume. In general, the more mixing volume, the better the mixing will be. For most pump systems, a 150 μ L cartridge will provide adequate mixing.

Examples of this type of pump system include:

Shimadzu LC-10AD and LC-10ADV
Beckman System Gold®
Gilson® Model 305
Agilent® Model 1100

Single-pump Low Pressure Mixing Gradient Systems

Linear Gradients

These systems generally require more mixing volume to perform linear gradients than multi-pump high pressure systems. The following will explain why this is the case. In a low pressure system the composition can only be changed once every pump stroke. Since the pump stroke volume of most pumps is 100 μL , and it takes a mixer volume that is about 3 times the batch volume to provide adequate mixing, we need 300 μL of mixer volume, at least, to do adequate mixing. More insoluble combinations may require even more mixing volume.

In general, choose the largest size mixer cartridge that will still provide an acceptable delay volume. For most applications this will be at least 350 μL .

Binary or Ternary – Steady State Composition

Always select the largest volume that will still provide an acceptable delay time. In general, the more mixing volume, the better the mixing will be. For most applications this will be at least 350 μL .

Examples of this type of pump system include:

Agilent® 1090
Perkin Elmer series 200
TSP Spectra Vision®
Waters model 626
Varian Star® 9000

Mixer Cartridge Selection Guide for High Pressure Mixing

Linear Gradients - High Pressure Mixing

Larger mixing volume can be tolerated for a particular flow rate, with the larger the volume the lower the mixing noise. The upper limits to mixing volume will be the maximum delay time that can be tolerated, and possible distortion (tailing) of the gradient at the beginning and end of the gradient. The lower limit will be defined by the amount of mixing noise that can be tolerated. The following cartridge volumes are a compromise between these two limits.

Table 1.

Flow	Mixer Cartridge Volume
0-5 micro liter/min.	5 micro liter
5-10	10
10-20	25
20-150	50
150-500	150
500+	250

Chart 1 Effect of Mixer Volume on Gradient Accuracy with a Constant Flow Rate

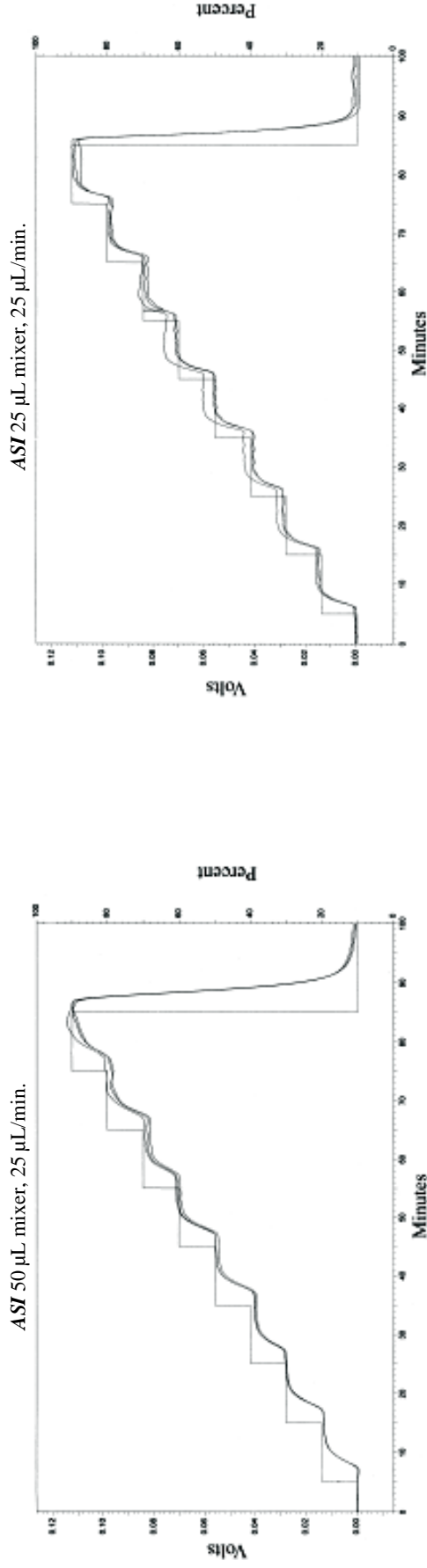

ASI 25 μL mixer, 25 $\mu\text{L}/\text{min}$.

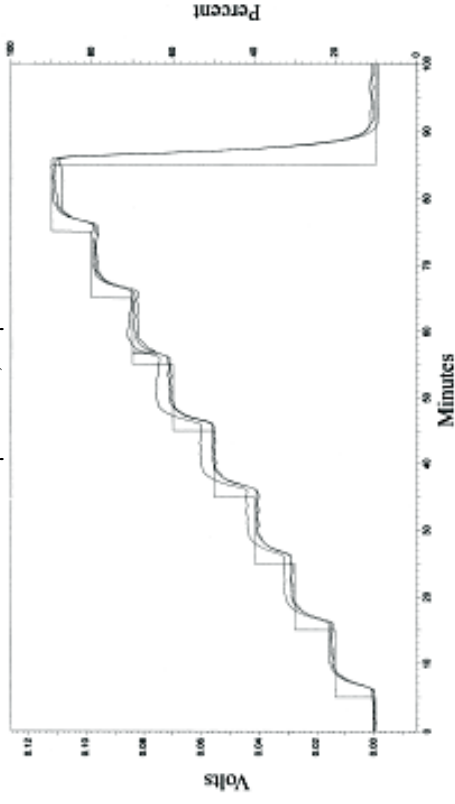

ASI 10 μL mixer, 25 $\mu\text{L}/\text{min}$.

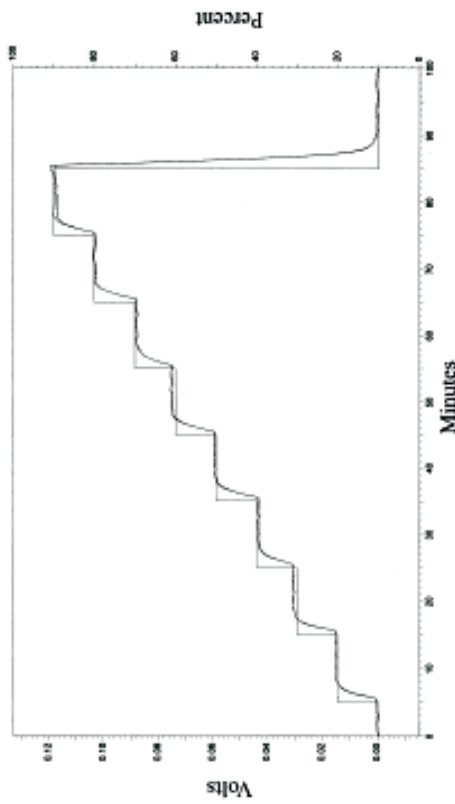

ASI 10 μL mixer, 25 $\mu\text{L}/\text{min}$.

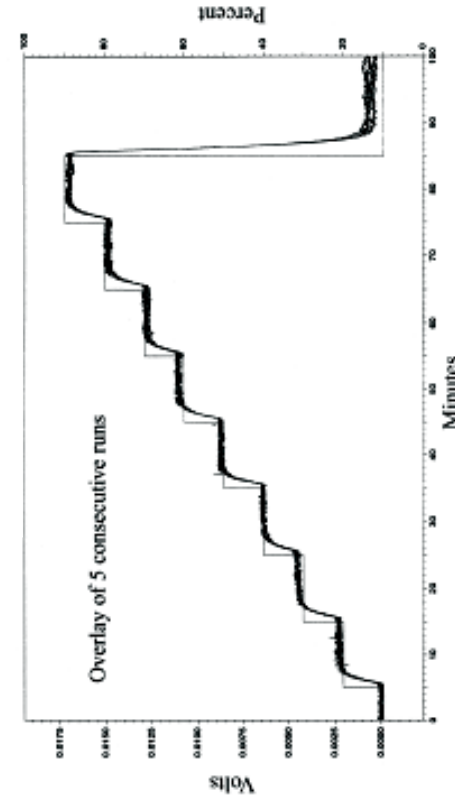

HPLC System configuration:

Shimadzu LC-10ADVP pumps with micro-flow modification
 Shimadzu SPD-10AVP UV-VIS detector
 Shimadzu Class-VP v5.03 software

HPLC conditions:

Gradient: 10-90% B in 10 min. steps
 A = H_2O
 B = 0.3% Acetone in H_2O

Chart 2 Effect of Flow Rate on Gradient Accuracy with a Constant Mixing Volume

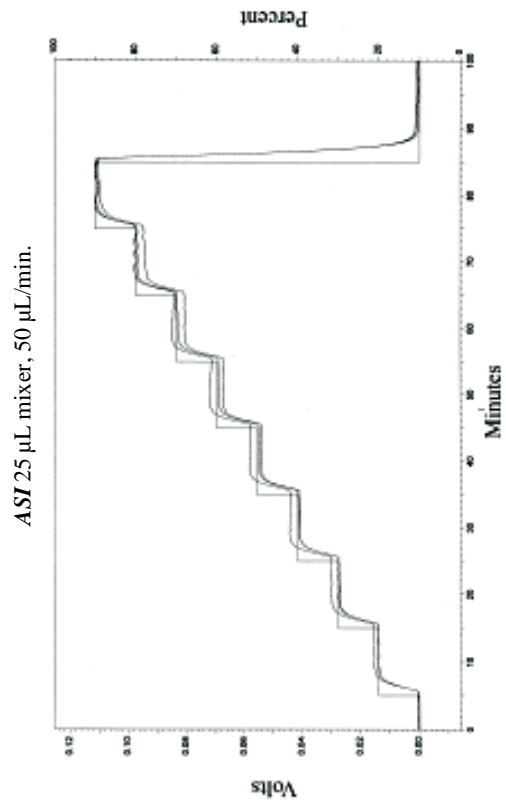
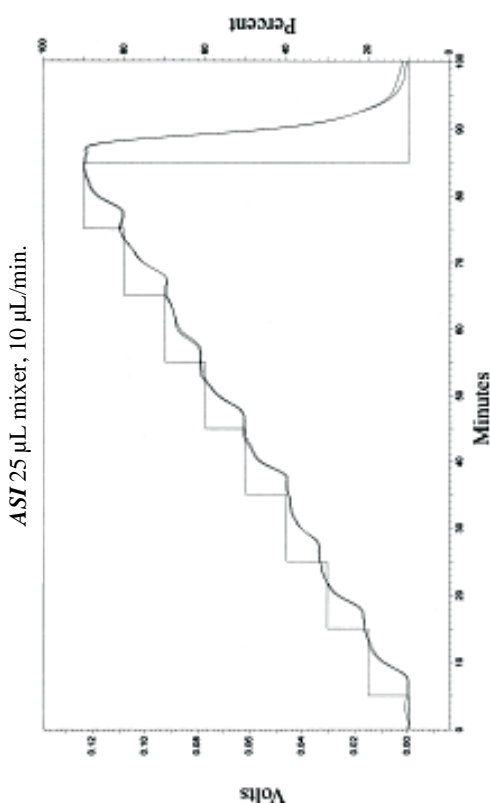
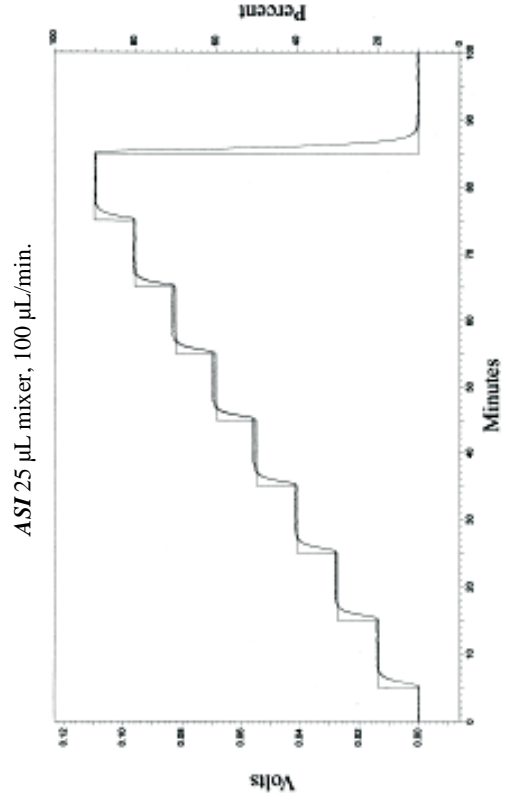
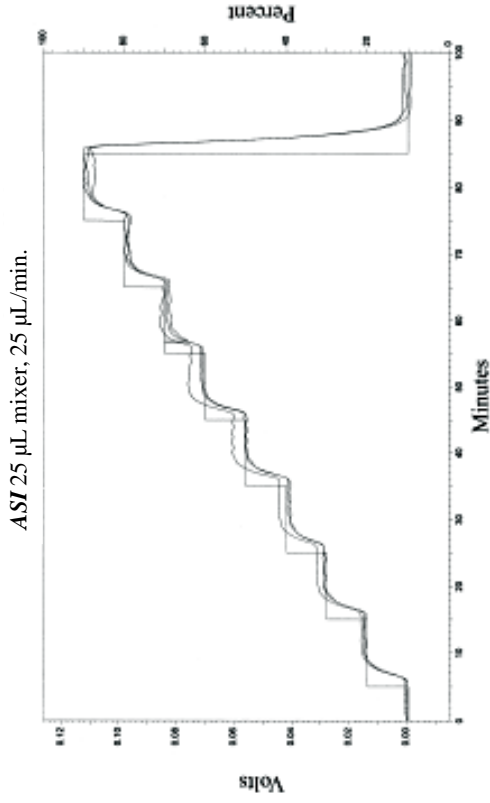

HPLC conditions:
 Gradient: 10-90% B in 10 min. steps
 A = H₂O
 B = 0.3% Acetone in H₂O

HPLC System configuration:
 Shimadzu LC-10ADVP pumps with micro-flow modification
 Shimadzu SPD-10AVP UV-VIS detector
 Shimadzu Class-VP v5.03 software

HyperShear Static Mixers

Binary Static Mixer Comparison -10 μ L

Less Noise - Lower Detection Limits

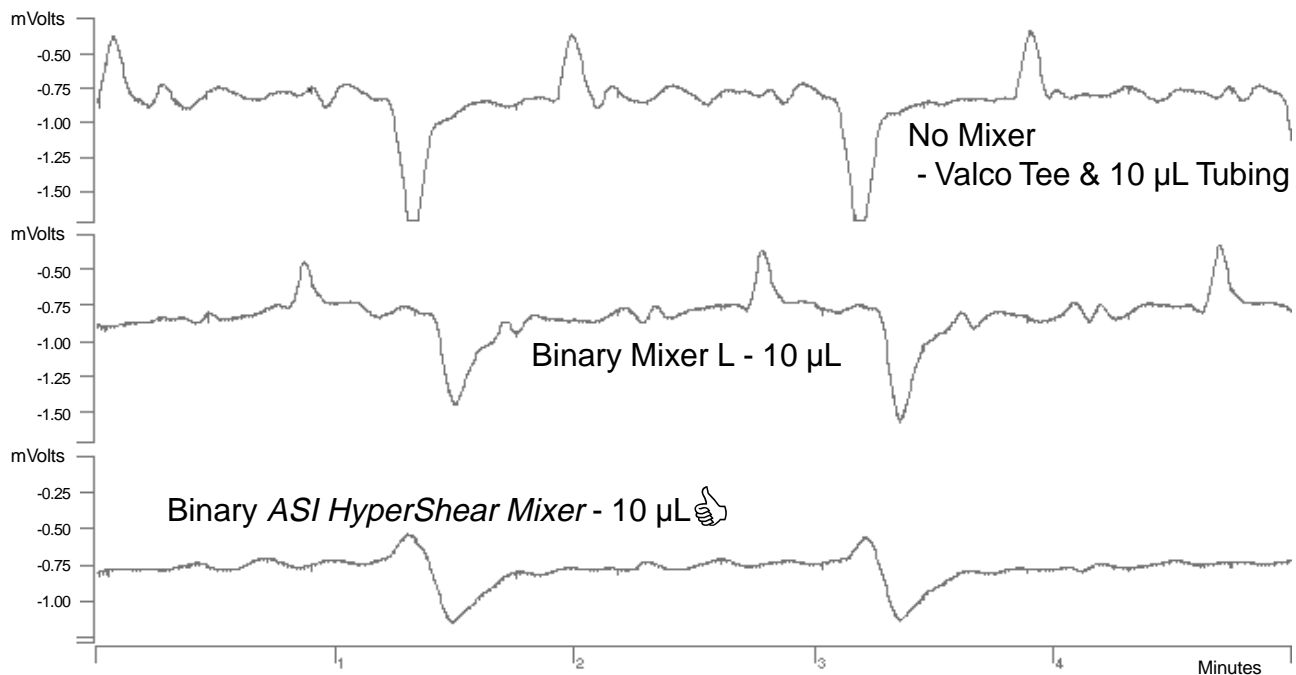

HPLC System Configuration:
ASI Model 500G Gradient System
ABI Model 785 UV/VIS @ 254 on-column
Varian Star Data Acquisition

HPLC Conditions:
MP: A = H₂O, B = H₂O/Acetone
Flow Rate: 50 μ L/min. 50% B
Pressure: 1,700 PSI with restrictor

Superior Mixing with Less Dispersion

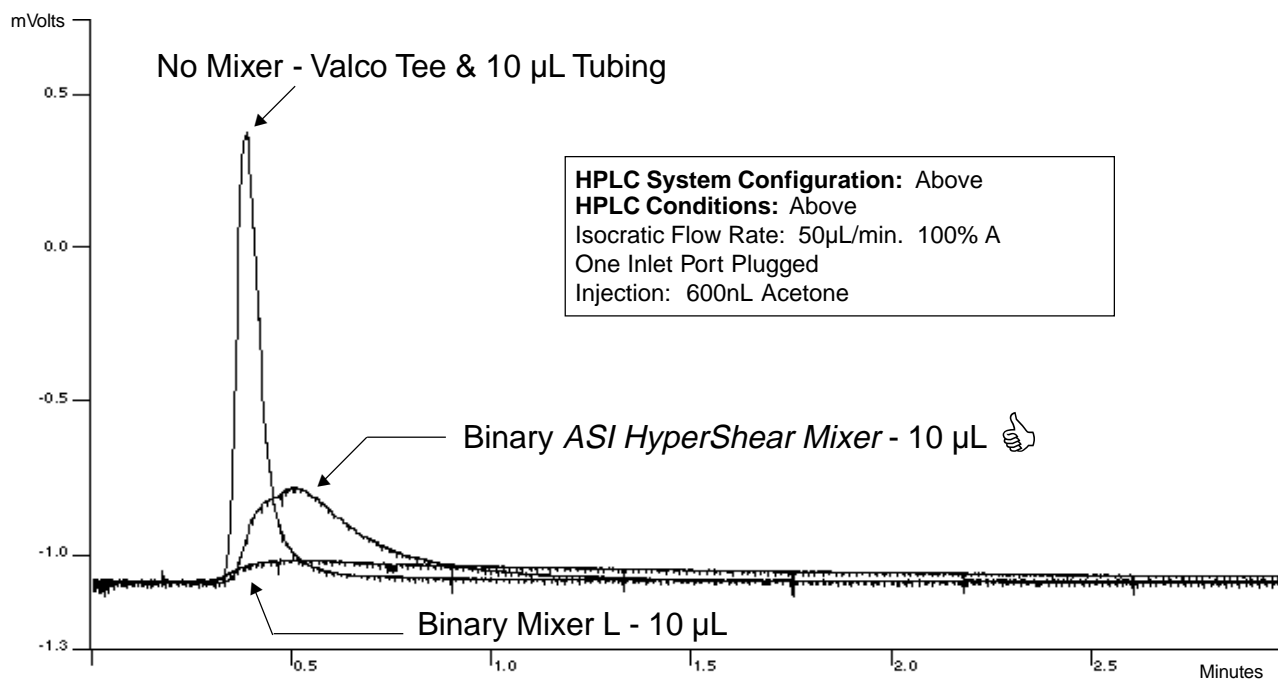

HPLC System Configuration: Above
HPLC Conditions: Above
Isocratic Flow Rate: 50 μ L/min. 100% A
One Inlet Port Plugged
Injection: 600nL Acetone

HyperShear™ Dynamic Mixers



HyperShear Dynamic Mixer, 1.0 mL



HyperShear Combination Static/Dynamic Mixer,
150 µL, 250 µL or 350 µL

HyperShear™ Dynamic Mixer Features:

- Vortex shear mixing that is twice as efficient as conventional stir bar mixers
- Models with fixed or adjustable mixing volumes
- Compact design allows easy integration into any HPLC system
- Available in 120 VAC or 220 VAC

Binary/Ternary Complete Assembly

Description	ASI Part Number
Binary Tee Dynamic Mixer Assembly 150 µL 120 VAC	462-0150A
Binary Tee Dynamic Mixer Assembly 150 µL 220 VAC	462-0150U
Binary Tee Dynamic Mixer Assembly 250 µL 120 VAC	462-0250A
Binary Tee Dynamic Mixer Assembly 250 µL 220 VAC	462-0250U
Binary Tee Dynamic Mixer Assembly 350 µL 120 VAC	462-0350A
Binary Tee Dynamic Mixer Assembly 350 µL 220 VAC	462-0350U
Binary Tee Dynamic Mixer Assembly 1.0 mL 120 VAC	462-1000A
Binary Tee Dynamic Mixer Assembly 1.0 mL 220 VAC	462-1000U
Ternary Tee Dynamic Mixer Assembly 1.0 mL 120 VAC	463-1000A
Ternary Tee Dynamic Mixer Assembly 1.0 mL 220 VAC	463-1000U

ASI Replacement Parts for HPLC Pumps

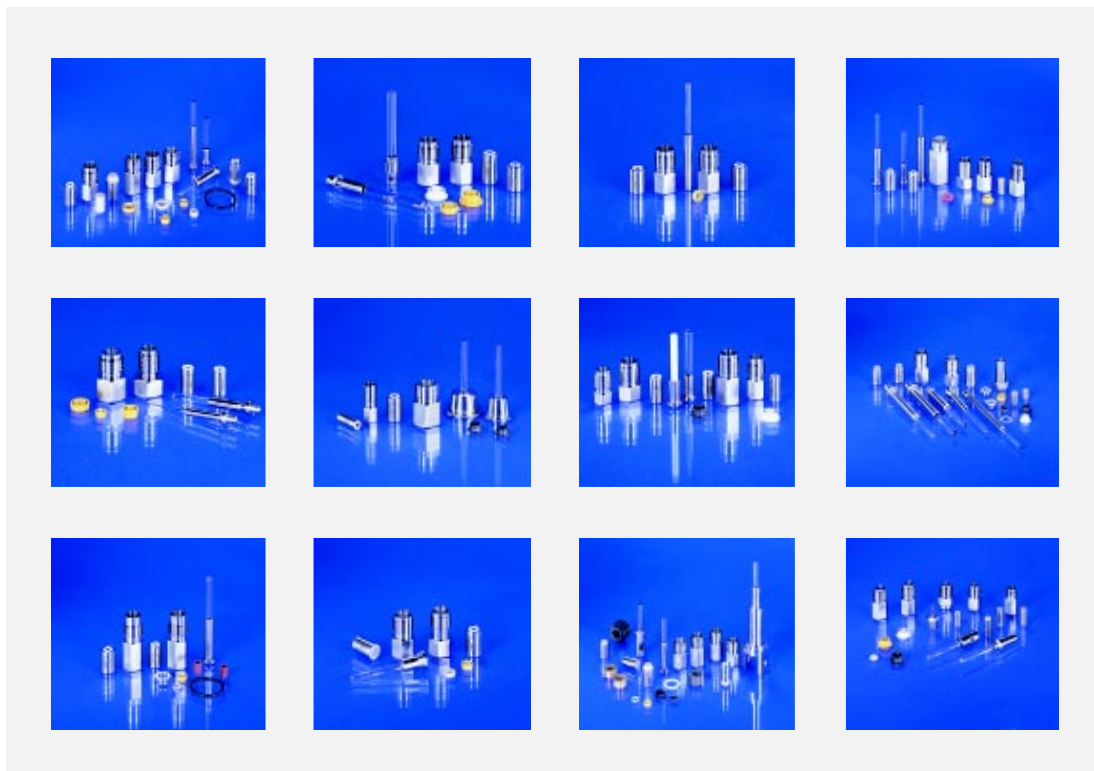

ASI Replacement Part Features:

- All check valves are self-priming, no external priming valve/syringe required
- Designed to deliver superior flow stability and accuracy
- Crush proof cartridge makes routine maintenance quick and easy
- Pistons are engineered to insure a high quality surface finish
- Seals are designed for long life, wide range of solvent compatibility, and optimum performance

ASI Replacement Parts for HPLC Pumps

Whether they are check valves, pistons or pump seals, all ASI replacement parts are designed to exceed the manufacturers specifications. All parts are subjected to rigorous engineering analysis and quality standards to insure the parts you purchase provide maximum life and superior chromatographic performance. Replacement parts are available for most HPLC pumps.

Table of Contents

ASI Self-priming Check Valves	54
ASI Replacement Piston Seals	56
ASI Replacement Pistons	57
Parts by Pump Manufacturer	
ABI/Kratos	58
Agilent	60
Beckman	62
Bio-Rad	64
Eldex	66
Gilson/Rainin	68
Hitachi	71
Jasco	73
LDC/Milton Roy	76
LKB	78
Perkin-Elmer	80
Shimadzu	83
Spectra-Physics/TSP	87
SSI	90
Varian	93
Waters	97
Other Pump Manufacturers	101
Installing ASI Check Valves	102
Maintenance and Trouble Shooting Tips	103
Trouble Shooting Guide	106

ASI Self-priming Check Valves

Why ASI Check Valves are the Best

➤ Self-priming

With the ASI valve, priming is easy. Open the pump outlet to release backpressure on the pump, and turn on the pump. Your pump will prime itself, even if the head and intake lines are completely dry. You won't need to use syringes or draw-off valves to prime your pump.

➤ Superior Flow Rate Stability

Because of the rapid and repeatable closure rate of the valve, the ball returns to the seat and seals before solvents have a chance to flow back through the valve. The result is a flow rate that is extremely repeatable and accurate, which means more repeatable retention times.

Please see the following data.

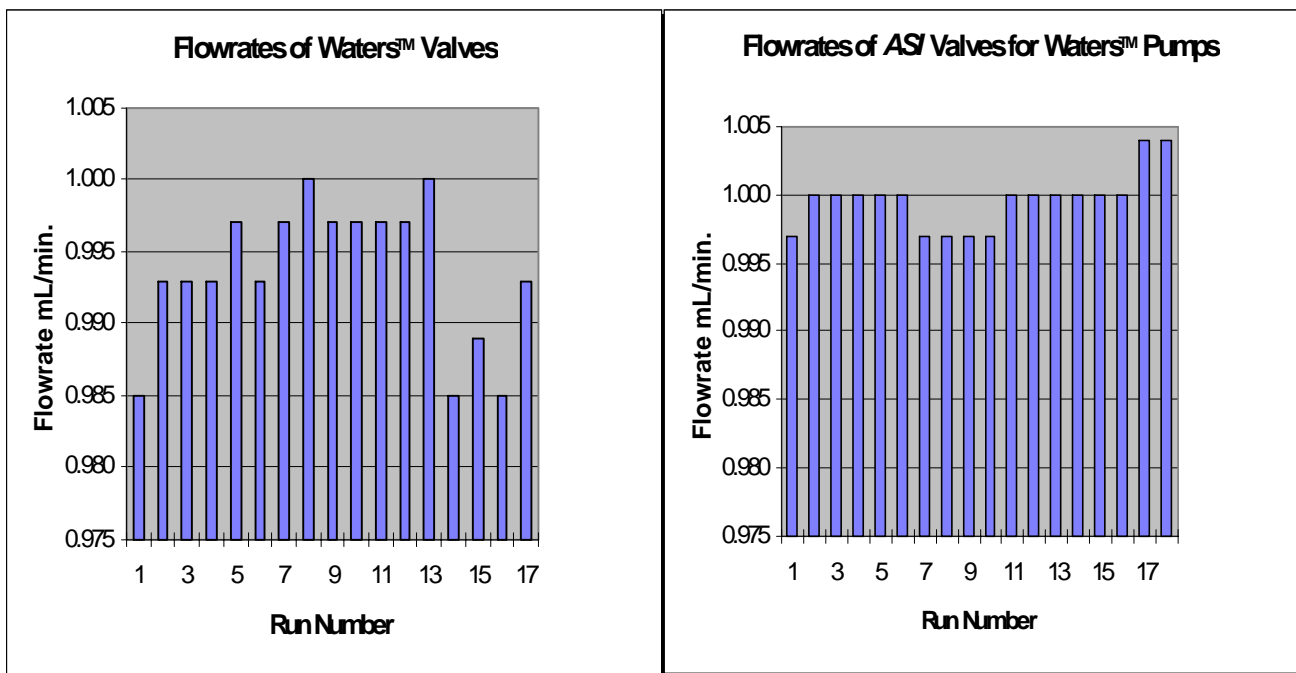

Data Certified by: Baseline Services, Mercerville, NJ May 21, 1997, Bodman Chromatography Aston, PA May 21, 1997

➤ Rugged Construction

The valve will not crush, crack or leak due to high pressure. We designed the ASI cartridge so that loads are transmitted through the valve casing rather than through the seat, as in conventional valves. The result is a valve that can withstand up to a 15,000 PSI continuous operating pressure, and will never fail no matter how much you tighten the housing (go ahead and try it – it's guaranteed!).

➤ **Pre-tested**

100 % ASI valves we ship must pass three stringent tests before it is shipped.

These tests are by far the most stringent in the HPLC industry, and indeed it is unlikely that any other valves would even pass these tests. But we do all these tests because we know how important it is to make sure that when you put a new valve in your pump, it will perform properly. After all, HPLC is hard enough as it is without worrying about your check valves!

1) Self-prime Test

This test uses a special pump test fixture that simulates an HPLC pump to verify that the valve is self-priming. After the test pump and intake line are purged of water, the valve must operate well enough so that the pump can draw water from a reservoir that is 36 inches below the pump intake. If the valve fails to prime, or “skips” even once during this test, it is rejected. This test not only guarantees that the valve will prime, but also that the valve will perform properly even at very low pressures, where most other valves do not work well.

2) High Pressure Leak Test

The valve is pressurized to 12,000 PSI and tested for leakage. Valves that exceed 50 nano liters per minute are rejected. This test not only insures valve integrity at very high pressures, but it also insures that the valve will still function properly even when the customer inadvertently over tightens the valve housing. We do not monitor nitrogen bubbles to measure leak rate, because a liquid can leak due to capillary action whereas gas will not. Besides, the chromatographer is pumping liquids, not gas!

3) Low Pressure Leak Test

The valve is pressurized to 500 PSI and tested for leakage. Valves that exceed 50 nano liters per minute are rejected. Most valves have difficulty closing and sealing properly in the absence of the large closing forces due to high pressure. ASI valves are designed so that they do not require any backpressure to operate properly, and this test verifies it.

➤ **Convenient and Economical Cartridge Design**

When it's time for routine maintenance, you only replace the cartridge, not the entire assembly. The ASI cartridge costs no more than most conventional valve rebuild kits, and you won't spend time chasing balls all over the lab bench.

ASI/Replacement Piston Seals

Selecting the Best Material for Your Application

ASI offers both UHMW-PE and Teflon compounds for pump seal jackets. The selection of the best material depends on a number of factors, which are discussed below.

UHMW-PE Compound

This material is based on ultra-high molecular weight polyethylene, and is compounded with other proprietary polymers to provide better lubricity and solvent resistance than pure UHMW-PE. This material is a self-lubricating compound that exhibits excellent wear characteristics, low coefficient of friction, and good resistance to cold-flow (extrusion). It is often used for “dry” bearings and seals, where lubrication by oil or other fluids is not permitted. It is resistant to most HPLC solvents except for methylene chloride and Toluene. UHMW-PE seals should only be used intermittently when using these solvents in 100 % concentration. ASI offers two different formulations of this material. One is a gold color and the other is white. The gold material is slightly stiffer than the white material, while the white material exhibits a slightly lower coefficient of friction. The formulation that we feel is most suitable for a specific pump model is the only formulation of UHMW-PE that we offer for that pump model. There are many different UHMW-PE formulations that appear the same color – but they are not all the same. We have subjected our materials to thousands of hours of testing to prove them out, and we are confident of their superior performance.

Teflon® Compound

This material is Teflon (PTFE) with a filler added to it for the purpose of increasing resistance to cold flow and improving wear characteristics. It is absolutely inert to any hplc solvent, but does not have the high resistance to wear and cold-flow that the UHMW-PE compounds have. It is more flexible than UHMW-PE, and therefore will conform better with pistons that are not aligned well, or which are worn flat. The color of our formulation is black. There are dozens of Teflon compounds, many of which are black, but they are not all the same. Some offer an extremely low coefficient of friction but wear rapidly, while others last longer but can rapidly wear the sapphire piston (such as ceramic filled Teflon). The selection of the Teflon compound that we use is based on thousands of hours of testing of compounds from several different suppliers, and we are confident that it offers the best performance.

Conclusion

In general we recommend using our UHMW-PE compound. It generates less wear material than Teflon, tends to act as a better bearing to help align the piston, and has a much longer service life than Teflon. Always inspect the piston for signs of scoring or wear when replacing seals. If your piston is worn or scratched- *replace it*- because nothing will destroy a seal faster than a worn or scratched piston. Refer to the section on pistons for advice on detecting a worn piston.

Piston Seal Installation

It is good practice to clean the pump head when replacing seals. Seal wear material will collect on the wetted surfaces of the head, and these will contaminate check valves and other downstream components. Always wet the seal and inside of the pump head with Isopropanol prior to installing the seal.

Please refer to the “Maintenance and Trouble Shooting Tips” on piston seals for more information (page 105).

ASI Replacement Pistons

It is hard to believe that sapphire, one of the hardest materials known to man, could ever be worn out or scratched by a soft material like Teflon or UHMW-PE. Unfortunately it does wear out. As the seal gets used, small particles of salt crystals, metal fragments, and other contaminants become embedded in the sealing surface of the seal. Over time these contaminants abrade the sapphire or ceramic plunger and form flat spots or longitudinal scratches. These wear spots will destroy any seal in a very short time.

It is extremely important to inspect the sapphire or ceramic plunger whenever you replace a seal. If there are any signs of scratches or glazed spots, replace the piston. Failure to do so will result in a shredded seal and a pump head full of seal wear material.

It is very difficult to see worn spots on a sapphire or ceramic piston. Hold the piston up to a bright light and inspect with a 10x magnifier or microscope. Any spot that appears dull, glazed, or scratched is a sure sign of a worn piston.

About ASI Pistons

Our sapphire and ceramic rods are 100 % inspected to ensure that there are no inclusions or other surface defects that may cause premature seal failure. We apply the same rigorous standards for quality control and close manufacturing tolerances that we maintain for our check valves.

Please refer to the “Maintenance and Trouble Shooting Tips” on pistons for more information (page 104).

Piston QC Tests and Instrumentation

Piston diameter	Digital micrometer
Piston length	Caliper
Geometry of ends	Shadowgraph 20X
Roundness	Talysurf
Surface finish	Talysurf
Groove (if any)	Shadowgraph 20X
Visual inspection	Binocular 25X

HIP Increases Density and Toughness

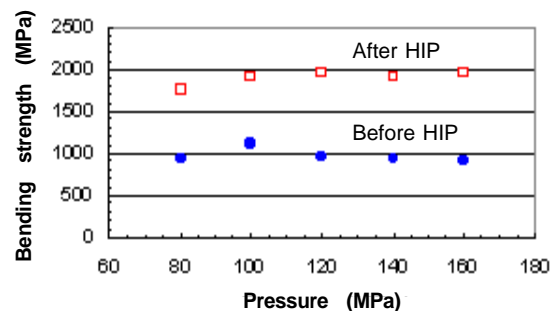



Replacement Check Valves

Self-priming With the *ASI* valve, priming is easy. Open the pump outlet and turn on the pump. Your pump will prime itself, even if the head and intake lines are completely dry. You won't need to use a syringe or draw-off valve to prime your pump.

Rugged Construction The valve will not crush, crack, or leak due to high pressure. We designed the *ASI* cartridge so that loads are transmitted through the valve casing rather than the seat, as in conventional designs.

Convenient and Economical Cartridge Design When it's time for routine maintenance, you only need to replace the cartridge, not the entire assembly. The *ASI* cartridge costs no more than most conventional valve rebuild kits, and you won't spend time chasing balls all over the lab bench.

Pre-tested Every *ASI* valve is tested prior to shipping to ensure it passes a stringent set of performance specifications.

Please see page 54 for more information about *ASI* check valves.

Replacement Piston Seals and Pistons

ASI pump seals and pistons have been developed to reduce pump downtime. Our UHMW-PE piston seal material is compounded with other proprietary polymers to provide lower friction and better solvent resistance than pure UHMW-PE. It generally provides much longer service life than Teflon and generates less wear material, and we recommend it for most applications. Our Teflon piston seal has a proprietary additive to increase resistance to cold flow, and improve wear characteristics. Teflon is inert to any HPLC mobile phase.

Please see page 56 for a detailed guide to selecting the best material.

ASI Self-priming Check Valves

ABI/Kratos Spectraflow 1400A, 1406A

Description	OEM Part Number	ASI Part Number
Inlet Check Valve (Cartridge & Housing)	7200-0060	250-1440*
Inlet Cartridge		250-1420*
Inlet Housing		250-1430
Outlet Check Valve (Cartridge & Housing)	7200-0062	250-1445*
Outlet Cartridge		250-1425*
Outlet Housing		250-1435
Replacement Filter 5/Pack		250-1220

* If you wish to specify ceramic ball & seat, add a "C" to end of part number.

ASI Replacement Piston Seals

ABI/Kratos Spectraflow 400, 1400A, 1406A

Description	OEM Part Number	ASI Part Number	Material
Piston Seal w/ Back-up Ring	7200-0088	200-1300	UHMW-PE
Piston Seal 10/Pack w/ Back-up Ring		200-1305	UHMW-PE

ASI Replacement Pistons

ABI/Kratos Spectraflow 400, 1400A, 1406A

Description	OEM Part Number	ASI Part Number	Material
Piston	1400-1970	260-1220	Sapphire Rod



Replacement Check Valves

Self-priming With the ASI valve, priming is easy. Open the pump outlet and turn on the pump. Your pump will prime itself, even if the head and intake lines are completely dry. You won't need to use a syringe or draw-off valve to prime your pump.

Rugged Construction The valve will not crush, crack, or leak due to high pressure. We designed the ASI cartridge so that loads are transmitted through the valve casing rather than the seat, as in conventional designs.

Convenient and Economical Cartridge Design When it's time for routine maintenance, you only need to replace the cartridge, not the entire assembly. The ASI cartridge costs no more than most conventional valve rebuild kits, and you won't spend time chasing balls all over the lab bench.

Pre-tested Every ASI valve is tested prior to shipping to ensure it passes a stringent set of performance specifications.

Please see page 54 for more information about ASI check valves.

Replacement Piston Seals and Pistons

ASI pump seals and pistons have been developed to reduce pump downtime. Our UHMW-PE piston seal material is compounded with other proprietary polymers to provide lower friction and better solvent resistance than pure UHMW-PE. It generally provides much longer service life than Teflon and generates less wear material, and we recommend it for most applications. Our Teflon piston seal has a proprietary additive to increase resistance to cold flow, and improve wear characteristics. Teflon is inert to any HPLC mobile phase.

Please see page 56 for a detailed guide to selecting the best material.

ASI Self-priming Check Valves

Agilent 1050, 1100

Description	OEM Part Number	ASI Part Number
Outlet Valves (Cartridge & Housing)	01018-60008	250-1417*
Outlet Cartridges		250-1397*
Outlet Housing		250-1407
Replacement Filter 5/Pack		250-1130

Agilent 1090

Description	OEM Part Number	ASI Part Number
Inlet Check Valve (Cartridge & Housing)	79835-25211 & 79835-67101	250-1410*
Inlet Cartridge		250-1390*
Inlet Housing		250-1400
Outlet Check Valve (Cartridge & Housing)	79835-25211 & 79835-67101	250-1415*
Outlet Cartridge		250-1395*
Outlet Housing		250-1405

* If you wish to specify ceramic ball & seat, add a "C" to end of part number.

ASI Replacement Piston Seals

Agilent 1050, 1100

Description	OEM Part Number	ASI Part Number	Material
Piston Seal	5062-8516 & 5063-6589	200-1357	Teflon
Piston Seal 10/Pack		200-1358	Teflon

Agilent 1090

Description	OEM Part Number	ASI Part Number	Material
Piston Seal	5062-2494	200-1367	Teflon
Piston Seal 10/Pack		200-1368	Teflon

ASI Replacement Pistons

Agilent 1050, 1100

Description	OEM Part Number	ASI Part Number	Material
Piston	5062-2441 & 5063-6586	260-1330	Sapphire Rod

Agilent 1090

Description	OEM Part Number	ASI Part Number	Material
Piston	3980-0672	260-1340	Sapphire Rod



Replacement Check Valves

Self-priming With the ASI valve, priming is easy. Open the pump outlet and turn on the pump. Your pump will prime itself, even if the head and intake lines are completely dry. You won't need to use a syringe or draw-off valve to prime your pump.

Rugged Construction The valve will not crush, crack, or leak due to high pressure. We designed the ASI cartridge so that loads are transmitted through the valve casing rather than the seat, as in conventional designs.

Convenient and Economical Cartridge Design When it's time for routine maintenance, you only need to replace the cartridge, not the entire assembly. The ASI cartridge costs no more than most conventional valve rebuild kits, and you won't spend time chasing balls all over the lab bench.

Pre-tested Every ASI valve is tested prior to shipping to ensure it passes a stringent set of performance specifications.

Please see page 54 for more information about ASI check valves.

Replacement Piston Seals and Pistons

ASI pump seals and pistons have been developed to reduce pump downtime. Our UHMW-PE piston seal material is compounded with other proprietary polymers to provide lower friction and better solvent resistance than pure UHMW-PE. It generally provides much longer service life than Teflon and generates less wear material, and we recommend it for most applications. Our Teflon piston seal has a proprietary additive to increase resistance to cold flow, and improve wear characteristics. Teflon is inert to any HPLC mobile phase.

Please see page 56 for a detailed guide to selecting the best material.

ASI Self-priming Check Valves

Beckman 100A, 110A/B, 112/M, 114/M, 116, 118, 125, 126, 127, 128

Description	OEM Part Number	ASI Part Number
Inlet Check Valve (Cartridge & Housing)	240720	250-1260*
Inlet Cartridge		250-1240*
Inlet Housing		250-1250
Outlet Check Valve (Cartridge & Housing)	240721	250-1265*
Outlet Cartridge		250-1245*
Outlet Housing		250-1255
Replacement Filter 5/Pack		250-1130

* If you wish to specify ceramic ball & seat, add a "C" to end of part number.

ASI Replacement Piston Seals

Beckman 100A, 110A, 110B

Description	OEM Part Number	ASI Part Number	Material
Piston Seal	887138	200-1240	UHMW-PE
Piston Seal 10/Pack		200-1241	UHMW-PE
Piston Seal Insertion Tool		200-1245	

Beckman 112, 112M

Description	OEM Part Number	ASI Part Number	Material
Piston Seal	236797	200-1255	UHMW-PE
Piston Seal 10/Pack		200-1256	UHMW-PE

Beckman 114, 114M, 116, 118, 125, 126, 127, 128

Description	OEM Part Number	ASI Part Number	Material
Piston Seal	241037	200-1250	UHMW-PE
Piston Seal 10/Pack		200-1251	UHMW-PE

ASI Replacement Pistons

Beckman 110A, 110B, 112, 112M

Description	OEM Part Number	ASI Part Number	Material
Piston Piston only	243053	260-1140	Sapphire Rod

Beckman 114, 114M, 116, 118, 125, 126, 127, 128

Description	OEM Part Number	ASI Part Number	Material
Piston Piston only	240714	260-1145	Sapphire Rod



Replacement Check Valves

Self-priming With the ASI valve, priming is easy. Open the pump outlet and turn on the pump. Your pump will prime itself, even if the head and intake lines are completely dry. You won't need to use a syringe or draw-off valve to prime your pump.

Rugged Construction The valve will not crush, crack, or leak due to high pressure. We designed the ASI cartridge so that loads are transmitted through the valve casing rather than the seat, as in conventional designs.

Convenient and Economical Cartridge Design When it's time for routine maintenance, you only need to replace the cartridge, not the entire assembly. The ASI cartridge costs no more than most conventional valve rebuild kits, and you won't spend time chasing balls all over the lab bench.

Pre-tested Every ASI valve is tested prior to shipping to ensure it passes a stringent set of performance specifications.

Please see page 54 for more information about ASI check valves.

Replacement Piston Seals and Pistons

ASI pump seals and pistons have been developed to reduce pump downtime. Our UHMW-PE piston seal material is compounded with other proprietary polymers to provide lower friction and better solvent resistance than pure UHMW-PE. It generally provides much longer service life than Teflon and generates less wear material, and we recommend it for most applications. Our Teflon piston seal has a proprietary additive to increase resistance to cold flow, and improve wear characteristics. Teflon is inert to any HPLC mobile phase.

Please see page 56 for a detailed guide to selecting the best material.

ASI Self-priming Check Valves

Bio-Rad 1330, 1350

Description	OEM Part Number	ASI Part Number
Inlet Check Valve (Cartridge & Housing)	125-0305	250-1170*
Inlet Cartridge		250-1150*
Inlet Housing		250-1160
Outlet Check Valve (Cartridge & Housing)	125-0307	250-1175*
Outlet Cartridge		250-1155*
Outlet Housing		250-1165
Replacement Filter 5/Pack		250-1130

* If you wish to specify ceramic ball & seat, add a "C" to end of part number.

ASI Replacement Piston Seals

Bio-Rad 1330, 1350

Description	OEM Part Number	ASI Part Number	Material
Piston Seal	125-0302	200-1230	UHMW-PE
Piston Seal 10/Pack		200-1231	UHMW-PE

ASI Replacement Pistons

Bio-Rad 1330, 1350

Description	OEM Part Number	ASI Part Number	Material
Piston	125-0304	260-1130	Sapphire Rod



Replacement Check Valves

Self-priming With the *ASI* valve, priming is easy. Open the pump outlet and turn on the pump. Your pump will prime itself, even if the head and intake lines are completely dry. You won't need to use a syringe or draw-off valve to prime your pump.

Rugged Construction The valve will not crush, crack, or leak due to high pressure. We designed the *ASI* cartridge so that loads are transmitted through the valve casing rather than the seat, as in conventional designs.

Convenient and Economical Cartridge Design When it's time for routine maintenance, you only need to replace the cartridge, not the entire assembly. The *ASI* cartridge costs no more than most conventional valve rebuild kits, and you won't spend time chasing balls all over the lab bench.

Pre-tested Every *ASI* valve is tested prior to shipping to ensure it passes a stringent set of performance specifications.

Please see page 54 for more information about *ASI* check valves.

Replacement Piston Seals and Pistons

ASI pump seals and pistons have been developed to reduce pump downtime. Our UHMW-PE piston seal material is compounded with other proprietary polymers to provide lower friction and better solvent resistance than pure UHMW-PE. It generally provides much longer service life than Teflon and generates less wear material, and we recommend it for most applications. Our Teflon piston seal has a proprietary additive to increase resistance to cold flow, and improve wear characteristics. Teflon is inert to any HPLC mobile phase.

Please see page 56 for a detailed guide to selecting the best material.

ASI Self-priming Check Valves

Eldex A, AA, B, E

Description	OEM Part Number	ASI Part Number
Inlet Check Valve (Cartridge & Housing)	1371	250-1330*
Inlet Cartridge		250-1310*
Inlet Housing		250-1320
Outlet Check Valve (Cartridge & Housing)	1372	250-1335*
Outlet Cartridge		250-1315*
Outlet Housing		250-1325
Replacement Filter 5/Pack		250-1220

* If you wish to specify ceramic ball & seat, add a "C" to end of part number.

ASI Replacement Piston Seals

Eldex A, AA, B, E

Description	OEM Part Number	ASI Part Number	Material
Piston Seal w/ Back-up Ring	1180/1181	200-1260	UHMW-PE
Piston Seal 10/Pack w/ Back-up Ring		200-1261	UHMW-PE

ASI Replacement Pistons

Eldex A, AA, B, E

Description	OEM Part Number	ASI Part Number	Material
Piston	5201	260-1160	Sapphire Rod



Replacement Check Valves

Self-priming With the ASI valve, priming is easy. Open the pump outlet and turn on the pump. Your pump will prime itself, even if the head and intake lines are completely dry. You won't need to use a syringe or draw-off valve to prime your pump.

Rugged Construction The valve will not crush, crack, or leak due to high pressure. We designed the ASI cartridge so that loads are transmitted through the valve casing rather than the seat, as in conventional designs.

Convenient and Economical Cartridge Design When it's time for routine maintenance, you only need to replace the cartridge, not the entire assembly. The ASI cartridge costs no more than most conventional valve rebuild kits, and you won't spend time chasing balls all over the lab bench.

Pre-tested Every ASI valve is tested prior to shipping to ensure it passes a stringent set of performance specifications.

Please see page 54 for more information about ASI check valves.

Replacement Piston Seals and Pistons

ASI pump seals and pistons have been developed to reduce pump downtime. Our UHMW-PE piston seal material is compounded with other proprietary polymers to provide lower friction and better solvent resistance than pure UHMW-PE. It generally provides much longer service life than Teflon and generates less wear material, and we recommend it for most applications. Our Teflon piston seal has a proprietary additive to increase resistance to cold flow, and improve wear characteristics. Teflon is inert to any HPLC mobile phase.

Please see page 56 for a detailed guide to selecting the best material.

ASI Self-priming Check Valves

Gilson/Rainin 5SC, 5WSS, 10SC, 10WSS

Description	OEM Part Number	ASI Part Number
Inlet Check Valve (Cartridge & Housing)	Gilson: 3645242 Rainin: E50131& R007101616	250-1380*
Inlet Cartridge		250-1360*
Inlet Housing		250-1370
Outlet Check Valve (Cartridge & Housing)	Gilson: 3645245 Rainin: E50121 & R007101617	250-1385*
Outlet Cartridge		250-1365*
Outlet Housing		250-1375
Replacement Filter 5/Pack		250-1220

Gilson/Rainin 25SC, 25WSS

Description	OEM Part Number	ASI Part Number
Inlet Check Valve (Cartridge & Housing)	Gilson: 3645242 Rainin: E50131& R007101616	250-1381*
Inlet Cartridge		250-1361*
Inlet Housing		250-1371
Outlet Check Valve (Cartridge & Housing)	Gilson: 3645245 Rainin: E50121 & R007101617	250-1386*
Outlet Cartridge		250-1366*
Outlet Housing		250-1376
Replacement Filter 5/Pack		250-1220

* If you wish to specify ceramic ball & seat, add a "C" to end of part number.

Gilson/Rainin

ASI Replacement Piston Seals

Gilson/Rainin 5SC, 5WSS, 5WTI, 5PK

Description	OEM Part Number	ASI Part Number	Material
Piston Seal	Gilson: 5463088863 Rainin: R007101634	200-1225	UHMW-PE
Piston Seal 10/Pack		200-1226	UHMW-PE

Gilson/Rainin 10SC, 10WSS, 10WTI, 10PK

Description	OEM Part Number	ASI Part Number	Material
Piston Seal	Gilson: 5463125895 Rainin: R007101637	200-1220	UHMW-PE
Piston Seal 10/Pack		200-1221	UHMW-PE

Gilson/Rainin 25SC, 25WSS, 25WTI, 25PK

Description	OEM Part Number	ASI Part Number	Material
Piston Seal	Gilson: 5463050825 Rainin: R007101643	200-1222	UHMW-PE
Piston Seal 10/Pack		200-1223	UHMW-PE

ASI Replacement Pistons

Gilson/Rainin 5SC, 5WSS, 5WTI, 5PK

Description	OEM Part Number	ASI Part Number	Material
Piston	Gilson: 3650008 Rainin: R007101657	260-1195	Sapphire Rod

Gilson/Rainin 10SC, 10WSS, 10WTI, 10PK

Description	OEM Part Number	ASI Part Number	Material
Piston	Gilson: 3650009 Rainin: R007101658	260-1190	Sapphire Rod

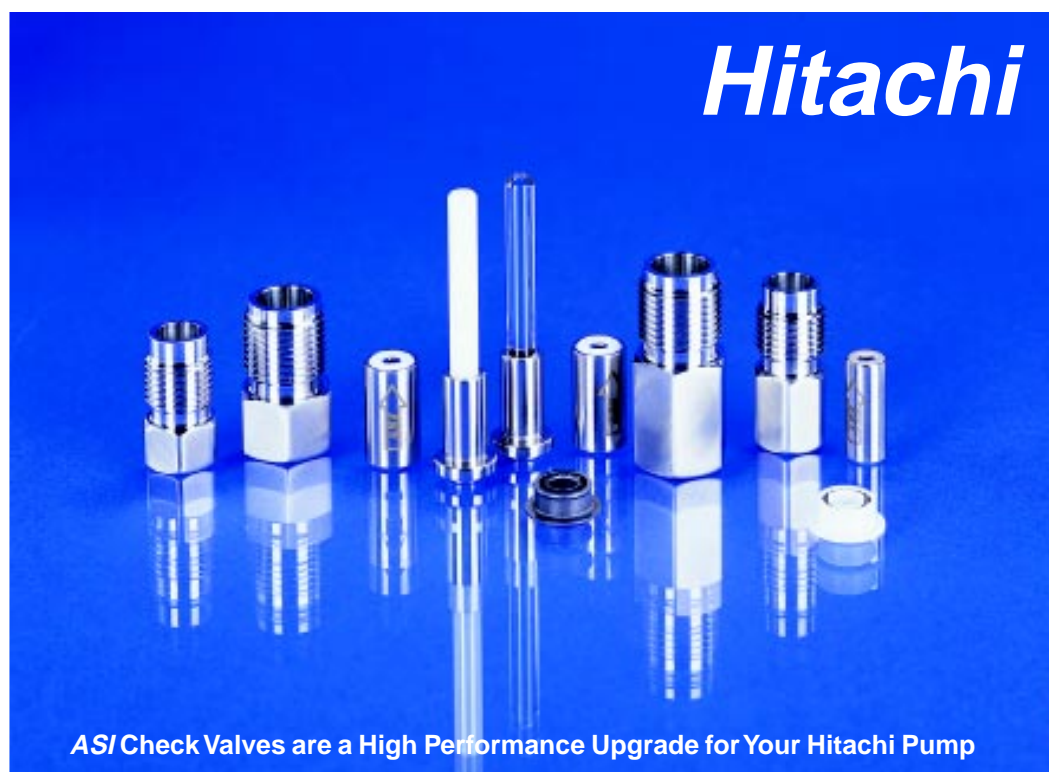

Replacement Check Valves

Self-priming With the ASI valve, priming is easy. Open the pump outlet and turn on the pump. Your pump will prime itself, even if the head and intake lines are completely dry. You won't need to use a syringe or draw-off valve to prime your pump.

Rugged Construction The valve will not crush, crack, or leak due to high pressure. We designed the ASI cartridge so that loads are transmitted through the valve casing rather than the seat, as in conventional designs.

Convenient and Economical Cartridge Design When it's time for routine maintenance, you only need to replace the cartridge, not the entire assembly. The ASI cartridge costs no more than most conventional valve rebuild kits, and you won't spend time chasing balls all over the lab bench.

Pre-tested Every ASI valve is tested prior to shipping to ensure it passes a stringent set of performance specifications.

Please see page 54 for more information about ASI check valves.

Replacement Piston Seals and Pistons

ASI pump seals and pistons have been developed to reduce pump downtime. Our UHMW-PE piston seal material is compounded with other proprietary polymers to provide lower friction and better solvent resistance than pure UHMW-PE. It generally provides much longer service life than Teflon and generates less wear material, and we recommend it for most applications. Our Teflon piston seal has a proprietary additive to increase resistance to cold flow, and improve wear characteristics. Teflon is inert to any HPLC mobile phase.

Please see page 56 for a detailed guide to selecting the best material.

ASI Self-priming Check Valves

Hitachi 655, L6000, L6200, L6200A

Description	OEM Part Number	ASI Part Number
Inlet Check Valve (Cartridge & Housing)	885-1330	250-1710*
Inlet Cartridge		250-1690*
Inlet Housing		250-1700
Outlet Check Valve (Cartridge & Housing)	885-1331	250-1715*
Outlet Cartridge		250-1695*
Outlet Housing		250-1705
Replacement Filter 5/Pack		250-1220

Hitachi L7100

Description	OEM Part Number	ASI Part Number
Inlet Check Valve (Cartridge & Housing)	AN0-0836	250-1680*
Inlet Cartridge		250-1660*
Inlet Housing		250-1670
Outlet Check Valve (Cartridge & Housing)	AN0-0835	250-1685*
Outlet Cartridge		250-1665*
Outlet Housing		250-1675

* If you wish to specify ceramic ball & seat, add a "C" to end of part number.

ASI Replacement Piston Seals

Hitachi 655, L6000, L6200, L6200A, L7100

Description	OEM Part Number	ASI Part Number	Material
Piston Seal	655-1080	200-1290	UHMW-PE
Piston Seal 10/Pack		200-1295	UHMW-PE
Piston Seal	655-1080	200-1297	Teflon
Piston Seal 10/Pack		200-1298	Teflon
Piston Seal Insertion Tool		200-1291	

ASI Replacement Pistons

Hitachi 655, L6000, L6200, L6200A, L7100

Description	OEM Part Number	ASI Part Number	Material
Piston	AN0-2328	260-1230	Sapphire Rod
Piston	AN0-2328	260-1230C	Ceramic Rod



Replacement Check Valves

Self-priming With the *ASI* valve, priming is easy. Open the pump outlet and turn on the pump. Your pump will prime itself, even if the head and intake lines are completely dry. You won't need to use a syringe or draw-off valve to prime your pump.

Rugged Construction The valve will not crush, crack, or leak due to high pressure. We designed the *ASI* cartridge so that loads are transmitted through the valve casing rather than the seat, as in conventional designs.

Convenient and Economical Cartridge Design When it's time for routine maintenance, you only need to replace the cartridge, not the entire assembly. The *ASI* cartridge costs no more than most conventional valve rebuild kits, and you won't spend time chasing balls all over the lab bench.

Pre-tested Every *ASI* valve is tested prior to shipping to ensure it passes a stringent set of performance specifications.

Please see page 54 for more information about *ASI* check valves.

Replacement Piston Seals and Pistons

ASI pump seals and pistons have been developed to reduce pump downtime. Our UHMW-PE piston seal material is compounded with other proprietary polymers to provide lower friction and better solvent resistance than pure UHMW-PE. It generally provides much longer service life than Teflon and generates less wear material, and we recommend it for most applications. Our Teflon piston seal has a proprietary additive to increase resistance to cold flow, and improve wear characteristics. Teflon is inert to any HPLC mobile phase.

Please see page 56 for a detailed guide to selecting the best material.

ASI Self-priming Check Valves

Jasco 880, 980

Description	OEM Part Number	ASI Part Number
Inlet Check Valve (Cartridge & Housing)	6688-H404A	250-0120*
Inlet Cartridge		250-0100*
Inlet Housing		250-0110
Outlet Check Valve (Cartridge & Housing)	6688-H405A	250-0125*
Outlet Cartridge		250-0105*
Outlet Housing		250-0115

Jasco BIP-1

Description	OEM Part Number	ASI Part Number
Inlet Check Valve (Cartridge & Housing)	6260-H101A	250-0150*
Inlet Cartridge		250-0130*
Inlet Housing		250-0140
Outlet Check Valve (Cartridge & Housing)	6260-H102A	250-0155*
Outlet Cartridge		250-0135*
Outlet Housing		250-0145

Jasco PU-1580

Description	OEM Part Number	ASI Part Number
Inlet Check Valve (Cartridge & Housing)	6778-H109A	250-0121*
Inlet Cartridge		250-0101*
Inlet Housing		250-0111
Outlet Check Valve (Cartridge & Housing)	6778-H110A	250-0126*
Outlet Cartridge		250-0106*
Outlet Housing		250-0116

* If you wish to specify ceramic ball & seat, add a "C" to end of part number.

ASI Replacement Piston Seals

Jasco 880, 980, BIP-1, PU-1580

Description	OEM Part Number	ASI Part Number	Material
Piston Seal	6560-H148A	200-0170	UHMW-PE
Piston Seal 10/Pack		200-0175	UHMW-PE
Piston Seal	6560-H148A	200-0171	Teflon
Piston Seal 10/Pack		200-0176	Teflon
Piston Seal Insertion Tool		200-0177	

ASI Replacement Pistons

Jasco 880, 980, BIP-1, PU-1580

Description	OEM Part Number	ASI Part Number	Material
Piston	2305-0009A	260-0170	Sapphire Rod



Replacement Check Valves

Self-priming With the ASI valve, priming is easy. Open the pump outlet and turn on the pump. Your pump will prime itself, even if the head and intake lines are completely dry. You won't need to use a syringe or draw-off valve to prime your pump.

Rugged Construction The valve will not crush, crack, or leak due to high pressure. We designed the ASI cartridge so that loads are transmitted through the valve casing rather than the seat, as in conventional designs.

Convenient and Economical Cartridge Design When it's time for routine maintenance, you only need to replace the cartridge, not the entire assembly. The ASI cartridge costs no more than most conventional valve rebuild kits, and you won't spend time chasing balls all over the lab bench.

Pre-tested Every ASI valve is tested prior to shipping to ensure it passes a stringent set of performance specifications.

Please see page 54 for more information about ASI check valves.

Replacement Piston Seals and Pistons

ASI pump seals and pistons have been developed to reduce pump downtime. Our UHMW-PE piston seal material is compounded with other proprietary polymers to provide lower friction and better solvent resistance than pure UHMW-PE. It generally provides much longer service life than Teflon and generates less wear material, and we recommend it for most applications. Our Teflon piston seal has a proprietary additive to increase resistance to cold flow, and improve wear characteristics. Teflon is inert to any HPLC mobile phase.

Please see page 56 for a detailed guide to selecting the best material.

ASI Self-priming Check Valves

LDC/Milton Roy All Analytical Pump Models

Description	OEM Part Number	ASI Part Number
Inlet Check Valve (Cartridge & Housing)	900947001	250-1300*
Inlet Cartridge		250-1280*
Inlet Housing		250-1290
Outlet Check Valve w/Adapter Seal (Cartridge & Housing)	900947002	250-1305*
Outlet Cartridge		250-1285*
Outlet Housing		250-1295
Adapter Seal for Outlet CV 5/Pack		250-1307-5
Replacement Filter 5/Pack		250-1130

* If you wish to specify ceramic ball & seat, add a "C" to end of part number.

ASI Replacement Piston Seals

LDC/Milton Roy All Analytical Pump Models

Description	OEM Part Number	ASI Part Number	Material
Piston Seal	206234	200-1280	UHMW-PE
Piston Seal 10/Pack		200-1285	UHMW-PE
Piston Seal	206234	200-1281	Teflon
Piston Seal 10/Pack		200-1286	Teflon
Replacement Kit Piston Seal 200-1280 Back-up Washer 2 Bushings O-Ring included	801892001	200-1287	UHMW-PE
Replacement Kit Piston Seal 200-1281 Back-up Washer 2 Bushings O-Ring included	801892001	200-1288	Teflon

ASI Replacement Pistons

LDC/Milton Roy All Analytical Pump Models

Description	OEM Part Number	ASI Part Number	Material
Piston	801306	260-1180	Sapphire Rod



Replacement Check Valves

Self-priming With the ASI valve, priming is easy. Open the pump outlet and turn on the pump. Your pump will prime itself, even if the head and intake lines are completely dry. You won't need to use a syringe or draw-off valve to prime your pump.

Rugged Construction The valve will not crush, crack, or leak due to high pressure. We designed the ASI cartridge so that loads are transmitted through the valve casing rather than the seat, as in conventional designs.

Convenient and Economical Cartridge Design When it's time for routine maintenance, you only need to replace the cartridge, not the entire assembly. The ASI cartridge costs no more than most conventional valve rebuild kits, and you won't spend time chasing balls all over the lab bench.

Pre-tested Every ASI valve is tested prior to shipping to ensure it passes a stringent set of performance specifications.

Please see page 54 for more information about ASI check valves.

Replacement Piston Seals and Pistons

ASI pump seals and pistons have been developed to reduce pump downtime. Our UHMW-PE piston seal material is compounded with other proprietary polymers to provide lower friction and better solvent resistance than pure UHMW-PE. It generally provides much longer service life than Teflon and generates less wear material, and we recommend it for most applications. Our Teflon piston seal has a proprietary additive to increase resistance to cold flow, and improve wear characteristics. Teflon is inert to any HPLC mobile phase.

Please see page 56 for a detailed guide to selecting the best material.

ASI Self-priming Check Valves

LKB 2150

Description	OEM Part Number	ASI Part Number
Inlet Check Valve (Cartridge & Housing)	80-1035-19	250-1860*
Inlet Cartridge		250-1840*
Inlet Housing		250-1850
Outlet Check Valve (Cartridge & Housing)	80-1035-20	250-1865*
Outlet Cartridge		250-1845*
Outlet Housing		250-1855
Replacement Filter 5/Pack		250-1130

* If you wish to specify ceramic ball & seat, add a "C" to end of part number.

ASI Replacement Piston Seals

LKB 2150

Description	OEM Part Number	ASI Part Number	Material
Piston Seal w/ Back-up Ring	80-1037-39	200-1330	UHMW-PE
Piston Seal 10/Pack w/ Back-up Ring		200-1335	UHMW-PE

ASI Replacement Pistons

LKB 2150

Description	OEM Part Number	ASI Part Number	Material
Piston	80-1035-52	260-1185	Sapphire Rod



Replacement Check Valves

Self-priming With the ASI valve, priming is easy. Open the pump outlet and turn on the pump. Your pump will prime itself, even if the head and intake lines are completely dry. You won't need to use a syringe or draw-off valve to prime your pump.

Rugged Construction The valve will not crush, crack, or leak due to high pressure. We designed the ASI cartridge so that loads are transmitted through the valve casing rather than the seat, as in conventional designs.

Convenient and Economical Cartridge Design When it's time for routine maintenance, you only need to replace the cartridge, not the entire assembly. The ASI cartridge costs no more than most conventional valve rebuild kits, and you won't spend time chasing balls all over the lab bench.

Pre-tested Every ASI valve is tested prior to shipping to ensure it passes a stringent set of performance specifications.

Please see page 54 for more information about ASI check valves.

Replacement Piston Seals and Pistons

ASI pump seals and pistons have been developed to reduce pump downtime. Our UHMW-PE piston seal material is compounded with other proprietary polymers to provide lower friction and better solvent resistance than pure UHMW-PE. It generally provides much longer service life than Teflon and generates less wear material, and we recommend it for most applications. Our Teflon piston seal has a proprietary additive to increase resistance to cold flow, and improve wear characteristics. Teflon is inert to any HPLC mobile phase.

Please see page 56 for a detailed guide to selecting the best material.

ASI Self-priming Check Valves

Perkin-Elmer Series 4, 200, 400, 410, 620, Model 250, Integral 4000

Description	OEM Part Number	ASI Part Number
Inlet Check Valve (Cartridge & Housing)	0254-0177	250-1800*
Inlet Cartridge		250-1780*
Inlet Housing		250-1790
Outlet Check Valve (Cartridge & Housing)	0254-0197	250-1805*
Outlet Cartridge		250-1785*
Outlet Housing		250-1795
Replacement Filter 5/Pack		250-1130

Perkin-Elmer Series 1, 2, 3, 3B, 10

Description	OEM Part Number	ASI Part Number
Inlet Check Valve (Cartridge & Housing)	0254-0546	250-1830*
Inlet Cartridge		250-1810*
Inlet Housing		250-1820
Outlet Check Valve (Cartridge & Housing)	0254-0547	250-1835*
Outlet Cartridge		250-1815*
Outlet Housing		250-1825

* If you wish to specify ceramic ball & seat, add a "C" to end of part number.

ASI Replacement Piston Seals

Perkin-Elmer Series 1, 2, 3, 3B, 4, 10, 200, 400, 410, 620, Model 250, Integral 4000

Description	OEM Part Number	ASI Part Number	Material
High Pressure Piston Seal w/ Back-up Ring & Back-up O-Ring	0990-7324	200-1512	UHMW-PE
High Pressure Piston Seal 10/Pack w/ Back-up Ring & Back-up O-Ring		200-1517	UHMW-PE
High Pressure Piston Seal w/ Back-up Ring & Back-up O-Ring	0990-7331	200-1510	Teflon
High Pressure Piston Seal 10/Pack w/ Back-up Ring & Back-up O-Ring		200-1515	Teflon
Low Pressure Piston Seal*	0990-7330	200-1520	Teflon
Low Pressure Piston Seal 10/Pack*		200-1525	Teflon
Low Pressure Piston Guide*	0254-2313	200-1521	
Wash Seal for Series 10		200-1530	UHMW-PE
Wash Seal for Series 10 10/Pack		200-1535	UHMW-PE

* Low pressure seals not available in Series 1, 2, 3, 3B, & 10

ASI Replacement Pistons

Perkin-Elmer Series 10

Description	OEM Part Number	ASI Part Number	Material
Self-flush Piston	0254-2442	260-1800	Sapphire Rod

Perkin-Elmer Series 4, 200, 400, 410, 620, Model 250, Integral 4000

Only units built after 12/89 for series 400, 410, 620

Description	OEM Part Number	ASI Part Number	Material
Piston (High Pressure) w/ Cam Follower Bearing & 2 Yoke Bushings	N260-0124	260-1830	Sapphire Rod
Piston (Low Pressure)	N260-0104	260-1840	Sapphire Rod

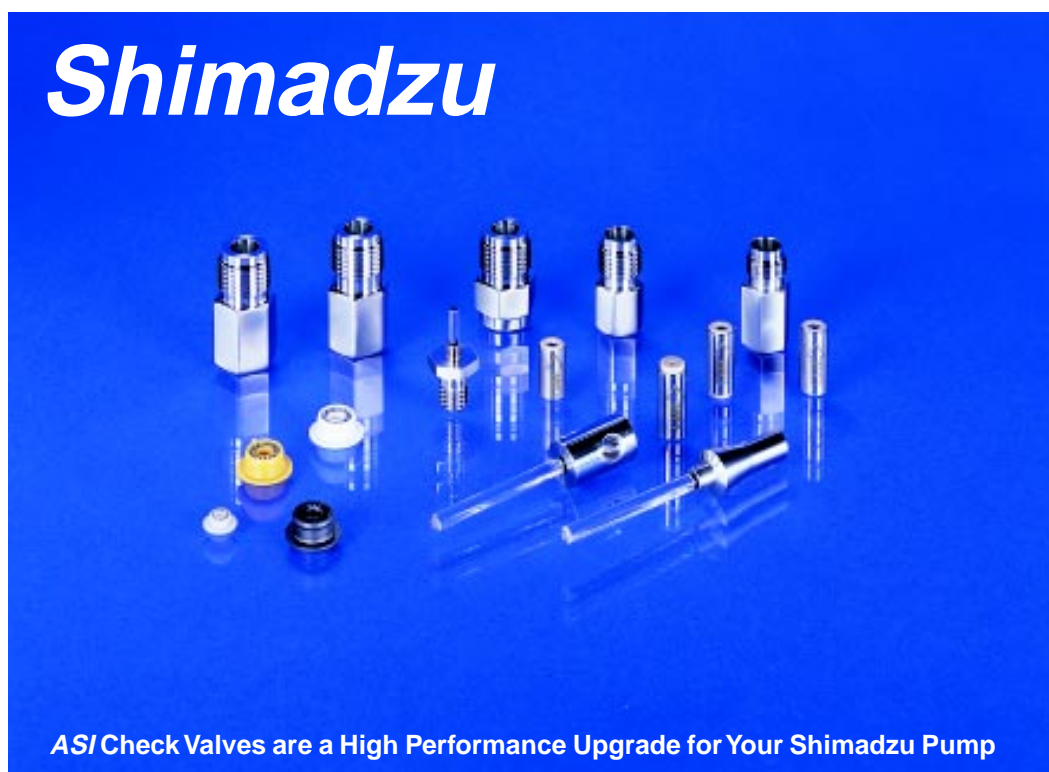

Replacement Check Valves

Self-priming With the ASI valve, priming is easy. Open the pump outlet and turn on the pump. Your pump will prime itself, even if the head and intake lines are completely dry. You won't need to use a syringe or draw-off valve to prime your pump.

Rugged Construction The valve will not crush, crack, or leak due to high pressure. We designed the ASI cartridge so that loads are transmitted through the valve casing rather than the seat, as in conventional designs.

Convenient and Economical Cartridge Design When it's time for routine maintenance, you only need to replace the cartridge, not the entire assembly. The ASI cartridge costs no more than most conventional valve rebuild kits, and you won't spend time chasing balls all over the lab bench.

Pre-tested Every ASI valve is tested prior to shipping to ensure it passes a stringent set of performance specifications.

Please see page 54 for more information about ASI check valves.

Replacement Piston Seals and Pistons

ASI pump seals and pistons have been developed to reduce pump downtime. Our UHMW-PE piston seal material is compounded with other proprietary polymers to provide lower friction and better solvent resistance than pure UHMW-PE. It generally provides much longer service life than Teflon and generates less wear material, and we recommend it for most applications. Our Teflon piston seal has a proprietary additive to increase resistance to cold flow, and improve wear characteristics. Teflon is inert to any HPLC mobile phase.

Please see page 56 for a detailed guide to selecting the best material.

ASI Self-priming Check Valves

Shimadzu LC-600, LC-9A, LC-10AD

Description	OEM Part Number	ASI Part Number
Inlet Check Valve (Cartridge & Housing)	228-18522-91	250-1480*
Inlet Cartridge		250-1460*
Inlet Housing		250-1470
Outlet Check Valve (Cartridge & Housing)	228-18522-92	250-1485*
Outlet Cartridge		250-1465*
Outlet Housing		250-1475

Shimadzu LC-6A, LC-10AS

Description	OEM Part Number	ASI Part Number
Inlet Check Valve (Cartridge & Housing)	228-12353-91	250-1482*
Inlet Cartridge		250-1462*
Inlet Housing		250-1472
Outlet Check Valve (Cartridge & Housing)	228-09054-93	250-1487*
Outlet Cartridge		250-1467*
Outlet Housing		250-1477

Shimadzu LC-10ADVP

Description	OEM Part Number	ASI Part Number
Inlet Check Valve (Cartridge & Housing)	228-39093-92	250-1481*
Inlet Cartridge		250-1461*
Inlet Housing		250-1471
Outlet Check Valve (Cartridge & Housing)	228-34976-91	250-1486*
Outlet Cartridge		250-1466*
Outlet Housing		250-1476

Shimadzu LC-10AT

Description	OEM Part Number	ASI Part Number
Inlet Check Valve (Cartridge & Housing)	228-32166-91	250-1484*
Inlet Cartridge		250-1464*
Inlet Housing		250-1474
Outlet Check Valve (Cartridge & Housing)	228-32531-92	250-1489*
Outlet Cartridge		250-1469*
Outlet Housing		250-1479

Shimadzu LC-10ATVP

Description	OEM Part Number	ASI Part Number
Inlet Check Valve (Cartridge & Housing)	228-32166-91	250-1483*
Inlet Cartridge		250-1463*
Inlet Housing		250-1473
Outlet Check Valve (Cartridge & Housing)	228-34976-91	250-1488*
Outlet Cartridge		250-1468*
Outlet Housing		250-1478

* If you wish to specify ceramic ball & seat, add a "C" to end of part number.

ASI Replacement Piston Seals**Shimadzu LC-600, LC-9A, LC-10AD, 10ADVP**

Description	OEM Part Number	ASI Part Number	Material
Piston Seal	228-18745-00 /228-35146-00	200-1420	Teflon
Piston Seal 10/Pack		200-1425	Teflon

Shimadzu LC-6A

Description	OEM Part Number	ASI Part Number	Material
Piston Seal	228-11999-00	200-1440	Teflon
Piston Seal 10/Pack		200-1445	Teflon
Piston Seal Insertion Tool		200-1441	

Shimadzu LC-7A, LC-10AS, LC-10AT, LC-10ATVP

Description	OEM Part Number	ASI Part Number	Material
Piston Seal	228-21975-00	200-1430	UHMW-PE
Piston Seal 10/Pack		200-1435	UHMW-PE
Piston Seal	228-35145-00	200-1432	Teflon
Piston Seal 10/Pack		200-1437	Teflon
Piston Wash Seal	228-28499-00	200-1431	UHMW-PE
Piston Wash Seal 10/Pack		200-1436	UHMW-PE

ASI Replacement Pistons

Shimadzu LC-600, LC-9A, LC-10AD

Description	OEM Part Number	ASI Part Number	Material
Piston	228-18523-91	260-1320	Sapphire Rod

Shimadzu LC-6A

Description	OEM Part Number	ASI Part Number	Material
Piston	228-12904-93	260-1310	Sapphire Rod

Shimadzu LC-7A, LC-10AS

Description	OEM Part Number	ASI Part Number	Material
Piston	228-17019-93	260-1305	Sapphire Rod

Shimadzu LC-10ATVP

Description	OEM Part Number	ASI Part Number	Material
Piston	228-35010-91	260-1302	Sapphire Rod

Shimadzu LC-10ADVP

Description	OEM Part Number	ASI Part Number	Material
Piston Piston only	228-35281-91	260-1303	Sapphire Rod



Replacement Check Valves

Self-priming With the *ASI* valve, priming is easy. Open the pump outlet and turn on the pump. Your pump will prime itself, even if the head and intake lines are completely dry. You won't need to use a syringe or draw-off valve to prime your pump.

Rugged Construction The valve will not crush, crack, or leak due to high pressure. We designed the *ASI* cartridge so that loads are transmitted through the valve casing rather than the seat, as in conventional designs.

Convenient and Economical Cartridge Design When it's time for routine maintenance, you only need to replace the cartridge, not the entire assembly. The *ASI* cartridge costs no more than most conventional valve rebuild kits, and you won't spend time chasing balls all over the lab bench.

Pre-tested Every *ASI* valve is tested prior to shipping to ensure it passes a stringent set of performance specifications.

Please see page 54 for more information about *ASI* check valves.

Replacement Piston Seals and Pistons

ASI pump seals and pistons have been developed to reduce pump downtime. Our UHMW-PE piston seal material is compounded with other proprietary polymers to provide lower friction and better solvent resistance than pure UHMW-PE. It generally provides much longer service life than Teflon and generates less wear material, and we recommend it for most applications. Our Teflon piston seal has a proprietary additive to increase resistance to cold flow, and improve wear characteristics. Teflon is inert to any HPLC mobile phase.

Please see page 56 for a detailed guide to selecting the best material.

ASI Self-priming Check Valves

Spectra-Physics 8100, 8700, 8800, 8810, IsoChrom

Description	OEM Part Number	ASI Part Number
Inlet Check Valve (Cartridge & Housing)	A3495-010	250-1210*
Inlet Cartridge		250-1190*
Inlet Housing		250-1200
Outlet Check Valve (Cartridge & Housing)	A3490-010	250-1215*
Outlet Cartridge		250-1195*
Outlet Housing		250-1205
Replacement Filter 5/Pack		250-1220

TSP SpectraSYSTEM® P1000, P2000, P3000, P4000

Description	OEM Part Number	ASI Part Number
Inlet Check Valve (Cartridge & Housing)	A3495-010	250-1210*
Inlet Cartridge		250-1190*
Inlet Housing		250-1200
Transducer Check Valve (Cartridge & Housing)	A3990-010	250-1217*
Transducer Cartridge		250-1197*
Transducer Housing		250-1207

* If you wish to specify ceramic ball & seat, add a "C" to end of part number.

ASI Replacement Piston Seals

**Spectra-Physics 8100, 8800, 8810, IsoChrom,
TSP SpectraSYSTEM® P1000, P2000, P3000, P4000**

Description	OEM Part Number	ASI Part Number	Material
Piston Seal	A2962-010 & A3070-010	200-1210	UHMW-PE
Piston Seal 10/Pack		200-1215	UHMW-PE
Flush Seal	A2963-010	200-1218	UHMW-PE
Flush Seal 10/Pack		200-1219	UHMW-PE

Spectra-Physics 8700

Description	OEM Part Number	ASI Part Number	Material
Piston Seal	A1703-020	200-2510	UHMW-PE
Piston Seal 10/Pack		200-2511	UHMW-PE

ASI Replacement Pistons

**Spectra-Physics 8100, 8800, 8810, IsoChrom,
TSP SpectraSYSTEM® P1000, P2000, P3000, P4000**

Description	OEM Part Number	ASI Part Number	Material
Piston	A3102-010	260-1100	Sapphire Rod

Spectra-Physics 8700

Description	OEM Part Number	ASI Part Number	Material
Piston	A1593-010	260-1105	Sapphire Rod



Replacement Check Valves

Self-priming With the ASI valve, priming is easy. Open the pump outlet and turn on the pump. Your pump will prime itself, even if the head and intake lines are completely dry. You won't need to use a syringe or draw-off valve to prime your pump.

Rugged Construction The valve will not crush, crack, or leak due to high pressure. We designed the ASI cartridge so that loads are transmitted through the valve casing rather than the seat, as in conventional designs.

Convenient and Economical Cartridge Design When it's time for routine maintenance, you only need to replace the cartridge, not the entire assembly. The ASI cartridge costs no more than most conventional valve rebuild kits, and you won't spend time chasing balls all over the lab bench.

Pre-tested Every ASI valve is tested prior to shipping to ensure it passes a stringent set of performance specifications.

Please see page 54 for more information about ASI check valves.

Replacement Piston Seals and Pistons

ASI pump seals and pistons have been developed to reduce pump downtime. Our UHMW-PE piston seal material is compounded with other proprietary polymers to provide lower friction and better solvent resistance than pure UHMW-PE. It generally provides much longer service life than Teflon and generates less wear material, and we recommend it for most applications. Our Teflon piston seal has a proprietary additive to increase resistance to cold flow, and improve wear characteristics. Teflon is inert to any HPLC mobile phase.

Please see page 56 for a detailed guide to selecting the best material.

ASI Self-priming Check Valves

SSI 200, 220, 222, 300, 350 SS

Description	OEM Part Number	ASI Part Number
Inlet Check Valve (Cartridge & Housing)	02-0162	250-1740*
Inlet Cartridge		250-1720*
Inlet Housing		250-1730
Outlet Check Valve (Cartridge & Housing)	02-0163	250-1745*
Outlet Cartridge		250-1725*
Outlet Housing		250-1735

SSI Accuflow Series 1, 2, 3, 4 SS

Description	OEM Part Number	ASI Part Number
Inlet Check Valve (Cartridge & Housing)	902242	250-1770*
Inlet Cartridge		250-1750*
Inlet Housing		250-1760
Outlet Check Valve (Cartridge & Housing)	902243	250-1775*
Outlet Cartridge		250-1755*
Outlet Housing		250-1765
Replacement Filter 5/Pack		250-1130

SSI Accuflow Series 1, 2, 3, 4 PEEK

Description	OEM Part Number	ASI Part Number
Inlet Cartridge PEEK Direct Replacement		250-1752*
Outlet Cartridge PEEK Direct Replacement		250-1757*

* If you wish to specify ceramic ball & seat, add a "C" to end of part number.

ASI Replacement Piston Seals

SSI 200, 220, 222, 300 Standard Head

Description	OEM Part Number	ASI Part Number	Material
Piston Seal	N/A	200-1340	UHMW-PE
Piston Seal 10/Pack		200-1345	UHMW-PE
Wash Seal	N/A	200-1344	UHMW-PE
Wash Seal 10/Pack		200-1349	UHMW-PE

SSI Accuflow Series 2, 3, 4

Description	OEM Part Number	ASI Part Number	Material
Piston Seal	901168	200-1342	UHMW-PE
Piston Seal 10/Pack		200-1343	UHMW-PE
Wash Seal	902029	200-1346	UHMW-PE
Wash Seal 10/Pack		200-1347	UHMW-PE
Replacement Kit Piston Seal, Piston Seal Back-up Ring, Wash Seal, Wash Seal Back-up Ring, O-Ring included	120680	200-1341	UHMW-PE

ASI Replacement Pistons

SSI 200, 220, 222, 300

Description	OEM Part Number	ASI Part Number	Material
Piston	12-0101	260-1205	Sapphire Rod
Self-flush Piston	12-0567	260-1200	Sapphire Rod

SSI Accuflow Series 2, 3, 4

Description	OEM Part Number	ASI Part Number	Material
Piston	12-1486	260-1210	Sapphire Rod



Replacement Check Valves

Self-priming With the ASI valve, priming is easy. Open the pump outlet and turn on the pump. Your pump will prime itself, even if the head and intake lines are completely dry. You won't need to use a syringe or draw-off valve to prime your pump.

Rugged Construction The valve will not crush, crack, or leak due to high pressure. We designed the ASI cartridge so that loads are transmitted through the valve casing rather than the seat, as in conventional designs.

Convenient and Economical Cartridge Design When it's time for routine maintenance, you only need to replace the cartridge, not the entire assembly. The ASI cartridge costs no more than most conventional valve rebuild kits, and you won't spend time chasing balls all over the lab bench.

Pre-tested Every ASI valve is tested prior to shipping to ensure it passes a stringent set of performance specifications.

Please see page 54 for more information about ASI check valves.

Replacement Piston Seals and Pistons

ASI pump seals and pistons have been developed to reduce pump downtime. Our UHMW-PE piston seal material is compounded with other proprietary polymers to provide lower friction and better solvent resistance than pure UHMW-PE. It generally provides much longer service life than Teflon and generates less wear material, and we recommend it for most applications. Our Teflon piston seal has a proprietary additive to increase resistance to cold flow, and improve wear characteristics. Teflon is inert to any HPLC mobile phase.

Please see page 56 for a detailed guide to selecting the best material.

ASI Self-priming Check Valves

Varian 2010, 2510

Description	OEM Part Number	ASI Part Number
Inlet Check Valve (Cartridge & Housing)	03-997261-09	250-1580*
Inlet Cartridge		250-1560*
Inlet Housing		250-1570
Outlet Check Valve (Cartridge & Housing)	03-997261-10	250-1585*
Outlet Cartridge		250-1565*
Outlet Housing		250-1575

Varian 5000, 5020, 5060

Description	OEM Part Number	ASI Part Number
Outlet Check Valve (Cartridge & Housing)	03-905201-00	250-1355*
Outlet Cartridge		250-1345*
Outlet Housing		250-1350
Replacement Filter 5/Pack		250-1130

Varian 9010, 9012, 9020, 220, 230, 240

Description	OEM Part Number	ASI Part Number
Outlet Check Valve (Cartridge & Housing)	03-919465-90	250-1555*
Outlet Cartridge		250-1535*
Outlet Housing		250-1545
Replacement Filter 5/Pack		250-1220

Varian ProStar SD200/300

Description	OEM Part Number	ASI Part Number
Inlet Check Valve 5, 10 mL/min. (Cartridge & Housing)	R007101616	250-1610*
Inlet Check Valve 25 mL/min. (Cartridge & Housing)	R007101616	250-1640*
Inlet Cartridge 5, 10 mL/min.		250-1590*
Inlet Cartridge 25 mL/min.		250-1620*
Inlet Housing 5, 10 and 25 mL/min.		250-1600
Outlet Check Valve 5, 10 mL/min. (Cartridge & Housing)	R007101617	250-1615*
Outlet Check Valve 25 mL/min. (Cartridge & Housing)	R007101617	250-1645*
Outlet Cartridge 5, 10 mL/min.		250-1595*
Outlet Cartridge 25 mL/min.		250-1625*
Outlet Housing 5, 10 and 25 mL/min.		250-1605

* If you wish to specify ceramic ball & seat, add a "C" to end of part number.

ASI Replacement Piston Seals

Varian 2010, 2510

Description	OEM Part Number	ASI Part Number	Material
Piston Seal	03-997261-37	200-1271	UHMW-PE
Piston Seal 10/Pack		200-1276	UHMW-PE

Varian 5000, 5020, 5060

Description	OEM Part Number	ASI Part Number	Material
Piston Seal w/ Back-up Washer	27-459633-00	200-1270	UHMW-PE
Piston Seal 10/Pack w/ Back-up Washer		200-1275	UHMW-PE

Varian 9010, 9012, 9020, 220, 230, 240

Description	OEM Part Number	ASI Part Number	Material
Piston Seal	03-919397-00	200-1278	UHMW-PE
Piston Seal 10/Pack		200-1279	UHMW-PE

Varian

Varian ProStar SD200/SD300

Description	OEM Part Number	ASI Part Number	Material
Piston Seal 5 mL/min.	Rainin: R007101634	200-1262	UHMW-PE
Piston Seal 5 mL/min. 10/Pack		200-1263	UHMW-PE
Piston Seal 10 mL/min.	Rainin: R007101637	200-1264	UHMW-PE
Piston Seal 10 mL/min. 10/Pack		200-1265	UHMW-PE
Piston Seal 25 mL/min.	Rainin: R007101643	200-1266	UHMW-PE
Piston Seal 25 mL/min. 10/Pack		200-1267	UHMW-PE

ASI Replacement Pistons

Varian 2010, 2510

Description	OEM Part Number	ASI Part Number	Material
Piston	03-997261-08	260-1171	Sapphire Rod

Varian 5000, 5020, 5060

Description	OEM Part Number	ASI Part Number	Material
Piston	03-905337-00	260-1170	Sapphire Rod

Varian 9010, 9012, 9020, 220, 230, 240

Description	OEM Part Number	ASI Part Number	Material
Piston	03-919180-00	260-1175	Sapphire Rod

Varian ProStar SD200/300

Description	OEM Part Number	ASI Part Number	Material
Piston for 5 mL/min.	Rainin: R007101657	260-1176	Sapphire Rod
Piston for 10 mL/min.	Rainin: R007101658	260-1177	Sapphire Rod

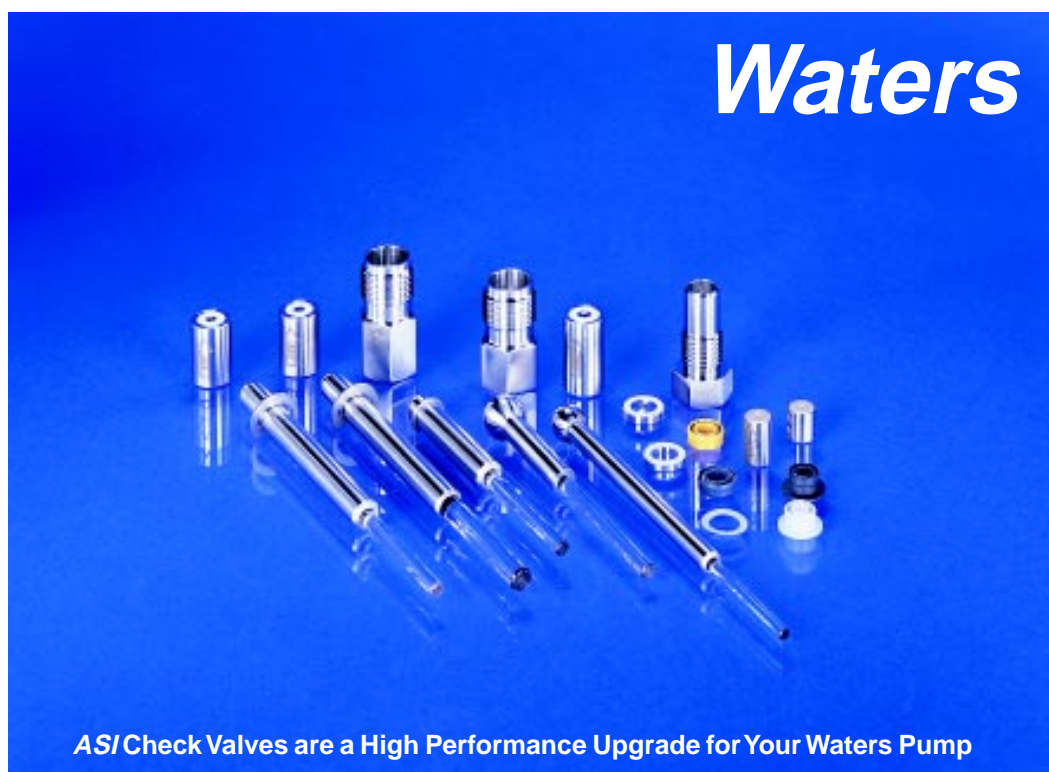

Replacement Check Valves

Self-priming With the ASI valve, priming is easy. Open the pump outlet and turn on the pump. Your pump will prime itself, even if the head and intake lines are completely dry. You won't need to use a syringe or draw-off valve to prime your pump.

Rugged Construction The valve will not crush, crack, or leak due to high pressure. We designed the ASI cartridge so that loads are transmitted through the valve casing rather than the seat, as in conventional designs.

Convenient and Economical Cartridge Design When it's time for routine maintenance, you only need to replace the cartridge, not the entire assembly. The ASI cartridge costs no more than most conventional valve rebuild kits, and you won't spend time chasing balls all over the lab bench.

Pre-tested Every ASI valve is tested prior to shipping to ensure it passes a stringent set of performance specifications.

Please see page 54 for more information about ASI check valves.

Replacement Piston Seals and Pistons

ASI pump seals and pistons have been developed to reduce pump downtime. Our UHMW-PE piston seal material is compounded with other proprietary polymers to provide lower friction and better solvent resistance than pure UHMW-PE. It generally provides much longer service life than Teflon and generates less wear material, and we recommend it for most applications. Our Teflon piston seal has a proprietary additive to increase resistance to cold flow, and improve wear characteristics. Teflon is inert to any HPLC mobile phase.

Please see page 56 for a detailed guide to selecting the best material.

ASI Self-priming Check Valves

Waters 616 SS

Description	OEM Part Number	ASI Part Number
Inlet Check Valve (Cartridge & Housing)	55845 & 24960	250-1060*
Inlet Cartridge Direct Replacement		250-1040*
Inlet Housing		250-1050
Outlet Check Valve (Cartridge & Housing)	55845 & 24960	250-1065*
Outlet Cartridge Direct Replacement		250-1045*
Outlet Housing		250-1055

Waters 625, 626 PEEK

Description	OEM Part Number	ASI Part Number
Inlet Cartridge Direct Replacement		250-1010*
Outlet Cartridge Direct Replacement		250-1015*

Waters Alliance® Model 2690

Description	OEM Part Number	ASI Part Number
Inlet Cartridge Direct Replacement		250-1070*
Outlet Cartridge Direct Replacement		250-1075*

Waters M45, 45G, 510, 515, 590, 6000, 6000A, LCM1

Description	OEM Part Number	ASI Part Number
Inlet Check Valve (Cartridge & Housing)	033679/700000253	250-1120*
Inlet Cartridge		250-1100*
Inlet Housing		250-1110
Outlet Check Valve w/Adapter Seal (Cartridge & Housing)	025216/700000253	250-1125*
Outlet Cartridge		250-1105*
Outlet Housing		250-1115
Adapter Seal for Outlet CV 5/Pack		250-1135-5
Replacement Filter 5/Pack		250-1130

Waters M501, 600, 600E, 610

Description	OEM Part Number	ASI Part Number
Inlet Check Valve (Cartridge & Housing)	033679/700000253	250-1120*
Inlet Cartridge		250-1100*
Inlet Housing		250-1110
Outlet Check Valve w/Adapter Seal (Cartridge & Housing)	025216/700000253	250-1127*
Outlet Cartridge		250-1105*
Outlet Housing		250-1115
Adapter Seal for Outlet CV 5/Pack		250-1137-5
Replacement Filter 5/Pack		250-1130

**Waters Extended Flow 225 µL Head #3
M510 EF, 590 EF, 6000 EF, 6000A EF, LCM1**

Description	OEM Part Number	ASI Part Number
Inlet Check Valve (Cartridge & Housing)	60307	250-1920*
Inlet Cartridge		250-1900*
Inlet Housing		250-1910
Outlet Check Valve w/Adapter Seal (Cartridge & Housing)	025216	250-1925*
Outlet Cartridge		250-1905*
Outlet Housing		250-1915
Adapter Seal for Outlet CV 5/Pack		250-1135-5
Replacement Filter 5/Pack		250-1130

**Waters Extended Flow 225 µL Head #3
M600 EF, 600E EF, 610 EF, 650 EF**

Description	OEM Part Number	ASI Part Number
Inlet Check Valve (Cartridge & Housing)	60307	250-1920*
Inlet Cartridge		250-1900*
Inlet Housing		250-1910
Outlet Check Valve w/Adapter Seal (Cartridge & Housing)	025216	250-1927*
Outlet Cartridge		250-1905*
Outlet Housing		250-1915
Adapter Seal for Outlet CV 5/Pack		250-1137-5
Replacement Filter 5/Pack		250-1130

* If you wish to specify ceramic ball & seat, add a "C" to end of part number.

ASI Replacement Piston Seals

Waters M45, 45G, 501, 510, 515, 590, 600, 600E, 610, 6000, 6000A, LCM1

Description	OEM Part Number	ASI Part Number	Material
Piston Seal w/ Teflon Gasket	022946	200-1202	UHMW-PE
Piston Seal w/ Teflon Gasket 10/Pack		200-1203	UHMW-PE
Piston Seal w/ Teflon Gasket	026613	200-1204	Teflon
Piston Seal w/ Teflon Gasket 10/Pack		200-1205	Teflon

Waters Extended Flow 225 µL Head #3

M510 EF, 590 EF, 600 EF, 600E EF, 610 EF, 650 EF, 6000 EF, 6000A EF, LCM1

Description	OEM Part Number	ASI Part Number	Material
Piston Seal	026644	200-1208	UHMW-PE
Piston Seal 10/Pack		200-1209	UHMW-PE
Piston Seal	026644	200-1206	Teflon
Piston Seal 10/Pack		200-1207	Teflon

ASI Replacement Pistons

Waters M45, 45G, 501

Description	OEM Part Number	ASI Part Number	Material
Piston	026524	260-1120	Sapphire Rod

Waters M510, 590, 600, 600E, 610, 6000, 6000A, LCM1

Description	OEM Part Number	ASI Part Number	Material
Piston	025656	260-1125	Sapphire Rod

Waters 616, 625, 626

Description	OEM Part Number	ASI Part Number	Material
Piston	031788	260-1240	Sapphire Rod

Waters Alliance® Model 2690

Description	OEM Part Number	ASI Part Number	Material
Piston	270959	260-1245	Sapphire Rod

Waters Extended Flow 225 µL Head #3

M510 EF, 590 EF, 600 EF, 600E EF, 610 EF, 650 EF, 6000 EF, 6000A EF, LCM1

Description	OEM Part Number	ASI Part Number	Material
Piston	060304	260-1110	Sapphire Rod

ASI Self-priming Check Valves

Bischoff 2200/2250, Alcott 760/765

Description	OEM Part Number	ASI Part Number
Inlet Check Valve (Cartridge & Housing)	2200-0220	250-1950*
Inlet Cartridge		250-1930*
Inlet Housing		250-1940
Outlet Check Valve (Cartridge & Housing)	2200-0230	250-1955*
Outlet Cartridge		250-1935*
Outlet Housing		250-1945

Tosoh C CPP-D

Description	OEM Part Number	ASI Part Number
Inlet Check Valve (Cartridge & Housing)	16807	250-0190*
Inlet Cartridge		250-0170*
Inlet Housing		250-0180
Outlet Check Valve (Cartridge & Housing)	16808	250-0195*
Outlet Cartridge		250-0175*
Outlet Housing		250-0185
Replacement Filter 5/Pack		250-1130

Tosoh C CPM-II

Description	OEM Part Number	ASI Part Number
Inlet Check Valve (Cartridge & Housing)	17717	250-0220*
Inlet Cartridge		250-0200*
Inlet Housing		250-0210
Outlet Check Valve (Cartridge & Housing)	17719	250-0225*
Outlet Cartridge		250-0205*
Outlet Housing		250-0215

Knauer K-1001, K-120, K-501

Description	OEM Part Number	ASI Part Number
Inlet/Outlet Cartridge	A0684	250-0260*

* If you wish to specify ceramic ball & seat, add a "C" to end of part number.

ASI Replacement Parts

Installing ASI Check Valves

The following are general instructions for all ASI check valves.

Inlet Check Valve

- 1.1 Disconnect solvent intake line and remove inlet valve.
- 1.2 Install inlet cartridge and housing with the arrow on the cartridge pointing up, in the flow direction.
- 1.3 Firmly tighten housing and reconnect inlet fitting.

Important: It is absolutely essential to use solvent inlet filters with at least a 10 micron rating or finer. Failure to use an inlet filter will seriously compromise the valve reliability.

Outlet Check Valve

- 1.1 Disconnect the solvent outlet line and remove the old check valve.
- 1.2 Install outlet cartridge and housing with the arrow on the cartridge pointing up.
- 1.3 Firmly tighten housing and reconnect outlet fitting.

Priming the Pump

- 1.1 Open the purge valve in order to eliminate any pressure in the pump head. If there is no purge valve, then loosen the fittings at the outlet check valve.
- 1.2 Operate the pump at 4.0 mL or higher (the higher the flow rate the faster the pump will prime).
- 1.3 The pump should now draw solvent and prime without further operator assistance. When no more air is seen venting from the outlet fittings or purge waste outlet, tighten the outlet fittings and close the purge valve.

Note: Running the seals dry while priming the pump will not cause damage to the seals. ASI piston seals are made from UHMW-PE or Teflon blends that are self-lubricating materials. However, filling the intake lines with as much solvent as possible prior to priming will save time.

Maintenance & Trouble Shooting Tips

The following tips are derived from our many years of working with HPLC pumps, and are presented here to assist the chromatographer or service technician to prevent problems from occurring, and diagnosing and solving them when they do occur.

Check Valves

■ Expected Service Life

The life of a check valve depends entirely upon service conditions. There are only three things that will compromise life of an ASI check valve: contamination from the mobile phase, contamination from pump seal wear material, and build-up of salts in the valve. If the guidelines below are adhered to, you can expect several years of reliable service from ASI valves (many of the ASI valves that were put into service for reliability testing in 1992 are still in service now).

However, for the best assurance of reliability and repeatable retention times, we recommend a policy of replacing the valves every second time the piston seals are replaced.

■ Keeping Them Clean

1. Solvent inlet filter

Always use a 10 micron or finer filter on the solvent intake line. Even if you use HPLC grade solvent, the solvent can become contaminated with dust particles by even a few hours of exposure to air in an open container. The reliability of a check valve can be seriously impaired by contamination. If you see your service technician “checking out” your pump and he is not using filters – **STOP HIM!** Even if the valves still work normally, your system is going to be contaminated!

2. Outlet valve filter

The purpose of the outlet valve filter is to guarantee reliability by preventing seal wear material and other contaminants from entering the outlet valve. For most chromatographers the added reliability is worth the extra effort to replace the filter every two or three years. However, users may elect to eliminate the outlet filter by substituting an inlet cartridge for an outlet, since for most pumps an ASI inlet valve is interchangeable with the outlet except for the filter. Please consult technical support if you need more information.

Inspect the filter on the outlet cartridge whenever you change a pump seal. If there is excessive residue on the filter, it is advisable to replace the filter. On most pumps the filter will last for at least 2 years before it needs to be changed, but if seals are wearing out frequently* then the filter life will be shorter due to a buildup of seal wear material.

***Please see page 109, “Seal Life Unusually Short.”**

3. Cleaning dirty valves

Use a syringe to flush the valve with 50 mL of clean HPLC grade IPA or water. This simple procedure works 90 % of the time. If not, then place the valve in 20 % nitric acid and sonicate for a maximum of 20 minutes. Follow this by flushing the valve with 50 mL of HPLC grade water (*wear safety goggles so you don't get acid in your eyes!*).

Note: Sonication will eventually cause fretting damage between the ball and seat, so do not sonicate more than 20 minutes.

ASI Replacement Parts

■ Long Term Storage: stuck check valves

Highly polished surfaces such as the sapphire, ruby or ceramic ball and seat in check valves will tend to bond to each other when allowed to dry out. The severity of this problem depends on what solvent was last in contact with the ball and seat. With acetonitrile, the problem is quite severe; with most other solvents the problem is not quite so noticeable but will still occur occasionally.

While this problem will almost never occur when valves are installed in a pump (it is virtually impossible for a valve to dry out while installed), it can occur during long-term storage. The best way to prevent this from happening is to store the valve in the original bag that the valve was shipped in, and filling the bag with several ml of isopropanol. Water can also be used as long as 20 % isopropanol is added to prevent biological growth. Valves that are stored in solvent (even acetonitrile) will not become stuck.

■ Diagnosing Valve Problems: distinguishing between inlet and outlet valve failure

Most valve problems are due to the inlet valve, since the outlet valve usually has a filter to protect it. If valve problems are suspected, the following test will help verify that the inlet valve is indeed the problem. Set the solvent bottle at the same level as the pump and introduce a small air bubble into the intake line. With the pump running under pressure, monitor progress of the bubble up the line. If the air bubble progresses towards the pump without any backward motion, then both inlet and outlet valves are working normally. If the air bubble moves back and forth in-sync with the pump stroke, then the inlet valve is failing to close properly. ***Please refer to the “Trouble Shooting Guide” (page 106) on check valves.***

If the air bubble does not move at all, then the outlet valve is suspect.

Please see page 108, “Failure to Prime”.

An excellent reference for general HPLC trouble shooting can be found in [Basic HPLC and CE of Biomolecules](#), by Robert Cunico, Karen Gooding, and Tim Wehr. This book is available from ASI, *please see page 111.*

Pistons

It is hard to believe that sapphire, one of the hardest materials known to man, could ever be worn out or scratched by a soft material like Teflon or UHMW-PE. Unfortunately it does wear out. As the seal gets used, small particles of salt crystals, metal fragments, and other contaminants become embedded in the sealing surface of the seal. Over time these contaminants abrade the sapphire or ceramic plunger and form flat spots or longitudinal scratches. These wear spots will destroy any seal in a very short time.

It is extremely important to inspect the sapphire or ceramic plunger whenever you replace a seal. If there are any signs of scratches or glazed spots, replace the piston. Failure to do so will result in a shredded seal and a pump head full of seal wear material.

It is very difficult to see worn spots on a sapphire or ceramic piston. Hold the piston up to a bright light and inspect with a 10x magnifier or microscope. Any spot that appears dull, glazed, or scratched is a sure sign of a worn piston.

Another problem that is not discussed as often is the design of the liquid end of the pump.

Some pumps are designed so that contact may occur between the piston and a metal or ceramic back-up ring. Such problems are usually due to a failure on the part of the pump designer to account for the accumulation of concentricity, or run-out tolerances between the piston and the metal back-up washers that support the seal. If you observe premature seal failure even after replacing your piston, then re-inspect the piston. If signs of scoring, or a glazed spot, appear on the new piston, then you may have a serious hardware design flaw that has nothing to do with your piston or seal. Contact ASI technical service for advice.

Piston Seals

■ Service Life

There are two ways that we define service life: one is when the leak rate becomes excessive (more than 1 % of set point flow rate); the other is when the seal begins to shed so much wear material that the valves and other hydraulic components begin to fail from contamination. We have run a number of life tests here at ASI comparing UHMW-PE to Teflon. In general, they both last equally long if you consider only the leak rate. The UHMW-PE wears less, but because it is a stiffer material it will not continue to conform to the piston when the inside sealing surface begins to wear away. On the other hand, Teflon wears much faster, but it is more compliant and so it continues to seal despite being badly worn. However, if you consider the shed rate of wear material as the criterion, then UHMW-PE is the clear winner because it sheds far less material than the Teflon compounds. Due to the importance and expense of the hydraulic components in the HPLC system, we firmly believe that when a seal generates an excessive amount of wear material its useful service life has been exceeded. Accordingly, the UHMW-PE compounds have a much greater service life than Teflon.

■ Seal Compliance

Teflon is a softer and more compliant material than UHMW-PE, so it will conform better to a worn or out-of-round piston. Also, if the piston is worn or scratched, it may leak whereas a Teflon seal might still work for a while (*but don't count on that for long – replace that worn piston ASAP!*). If your newly installed UHMW-PE seals do leak when they are first installed, run the pump at 2,000 PSI or more for 30 minutes with IPA or Water, and the leak will stop as the seal conforms to the seal cavity and piston. If the leak doesn't stop after 30 minutes, then it was either damaged during installation or the piston is worn or scratched and must be replaced.

■ Solvent Compatibility

Teflon is absolutely inert to any HPLC solvent, period. UHMW-PE compounds may exhibit reduced life when used with very strong organic solvents like pure methylene chloride and toluene. However, it is important to bear in mind that solvent compatibility is a rather minor issue when compared to other factors such as what pump you have, the condition of the piston, and whether the seal was damaged during installation.

■ Installation

If the seal is badly worn, then the pump head will be contaminated with seal wear material. Remove the check valves and seal from the pump head and sonicate the head in 20 % nitric acid for 30 minutes. Rinse thoroughly, then sonicate for 10 minutes in DI water. Blow dry with oil free compressed gas or air. The inlet valve should be flushed with 50 mL of HPLC grade isopropanol or water, and the outlet valve filter inspected (if there is no filter on the outlet, then flush with 50 mL of HPLC grade IPA or water). Carefully inspect the piston for worn spots or scratches.

Please refer to piston section (page 104).

Wet the seal and pump head with isopropanol prior to reassembly. IPA serves both as a lubricant and surface wetting agent, which will reduce the amount of air trapped in the head.

Install the new seal, using an installation tool if available. Use great caution not to damage the lip of the seal during installation.

Run the pump with IPA at about 2,000 PSI for 30 minutes to set the seal.

If the seal leaks after the first 30 minutes:

1. Check that the seal lip was not damaged during installation.
2. Carefully examine the piston for wear or scratches. It is difficult to detect a damaged or worn piston. Use a magnifying glass to identify any glazed or "frosted" spots, axial grooves or scratches. When in doubt, replace the piston.

Trouble Shooting Guide

The following trouble shooting guide has been prepared for the novice as well as experienced service technicians. Often it is more expedient to simply replace old parts with new ones and get back to work, but for the chromatographer who doesn't have the budget for that, or who is down on a weekend with no spare parts, we hope these tips get your HPLC pump up and running, and keep it running.

Problem	Cause	Remedy
Erratic Pressure	Dirty inlet valve	Remove inlet valve and flush with 50 mL of clean HPLC grade solvent.
	Dirty outlet valve	Replace with new valve (an inlet cartridge can be substituted for an outlet if no outlet valves are available). If there is no filter on the outlet, then it may be cleaned in the same manner as an inlet.
	Clogged solvent intake filter	Replace with new filter.
	Leak at solvent inlet line	Tighten fitting. Replace ferrule and fitting if no longer serviceable.
		Note: This problem may not be easy to detect! On the intake side of the pump there is a slight vacuum, so air will leak into the pump rather than solvent leaking out. There will be no visible sign of a leak. To detect this problem, make sure that there is no air in the intake lines, then open the outlet fitting and watch for air bubbles coming out (place a drop of solvent at the outlet fitting to observe air bubbles). If you continue to observe air bubbles after 60 seconds, then air is probably entering the head from the inlet fitting, a leaky pump seal, or an insufficiently tightened inlet housing.
	Worn pump seal or piston	Replace seal. Inspect piston and replace if worn.
		Note: If your piston is worn, you can sometimes get a Teflon seal to work for a short time, until a new piston can be obtained. Teflon will generally conform to and seal with a worn piston better than UHMW-PE, but not for long. Also, Teflon will generate copious amounts of wear material when used with a worn piston. Replace the worn piston ASAP.

Problem	Cause	Remedy
<p>Erratic Pressure continued</p>	<p>Air in pump head</p> <p><i>Note: This symptom is normal after replacing a pump seal or piston. Wet the seal and inside of the pump head with IPA to reduce the amount of time it takes to eliminate air from the head.</i></p> <p>Not using degassed solvents</p> <p>Air bubbles in inlet line</p>	<p>Purge pump for 30 seconds, then operate at 1,000 PSI or higher. The air will dissolve in the solvent and be expelled within about 30 minutes.</p> <p>Degas, preferably using vacuum and sonication.</p> <p>Degas solvent. Replace solvent inlet filter. Make sure solvent bottle still has solvent!</p>
<p>Frequent Check Valve Failure</p>	<p>Contaminated solvent</p> <p>No solvent inlet filter</p> <p>Worn pump seal or Piston</p> <p><i>Note: If the seal is badly worn, then the pump head will be contaminated with seal wear material. Remove the check valves and seal from head and sonicate the head in 20 % nitric acid for 30 minutes. Rinse thoroughly, then sonicate for 10 minutes in DI water. Wet seal and pump head with IPA prior to reassembly. The inlet valve should be flushed with 50 mL of HPLC grade IPA or Water, and the outlet valve filter inspected (if there is no filter on the outlet, then flush with 50 mL HPLC solvent).</i></p> <p>Service life of check valves has been exceeded</p>	<p>Use clean HPLC grade solvent.</p> <p>Always use 10 micron or finer solvent filter.</p> <p>Replace seal. Inspect piston and replace if worn.</p> <p>Install new valves.</p>

ASI Replacement Parts

Problem	Cause	Remedy
Failure to Prime	Excess back pressure in pump head	Open purge valve, or open fittings at outlet check valve.
	Valve installed upside down	Verify that arrow faces up for both inlet and outlet valve.
	Clogged solvent inlet filter	Clean or replace with new filter.
	Clogged outlet valve filter	Replace outlet valve filter.
	<p>Note: The outlet valve filter should last at least 2 years in normal service. However, if piston seals are wearing out frequently, then wear material from the seal may cause premature clogging of the outlet frit, as well as contaminating the inlet valve. Replace the outlet filter, and inspect the sapphire piston for wear or score marks.</p>	
Operating Pressure is Lower than Normal	Worn seal or piston	Replace seal. Inspect piston and replace if worn.
	Air in pump head or intake line	Purge pump for 30 seconds, then operate at 1,000 PSI or higher. The air will dissolve in the solvent and be expelled within about 30 minutes.
	Clogged solvent inlet filter	Clean or replace with new filter.
	Dirty inlet valve	Remove inlet valve and flush with 50 mL of clean HPLC grade solvent.
	Dirty outlet valve	Replace with new valve (an inlet cartridge can be substituted for an outlet if no outlet valves are available). If there is no filter on the outlet, then it may be cleaned in the same manner as an inlet.

Problem	Cause	Remedy
<p>Operating Pressure is Lower than Normal continued</p>	<p>Leaky fitting</p> <p>Note: <i>If a slight amount of additional tightening does not slow stop the leak, then replace the ferrule. Over-tightening the fitting can damage the seat, strip the threads, or worse, cause the nut to shear off. Never exceed 15 in-lbs of torque.</i></p>	<p>Tighten fitting. Replace ferrule if badly deformed.</p>
<p>Seal Life Unusually Short</p>	<p>Worn or scratched piston</p> <p>Note: <i>It is not always obvious by visual inspection if a piston is worn or scratched. Use a magnifying glass to look for a glazed appearance, or axial grooves and scratches. The piston is badly worn if any such conditions are visible.</i></p> <p>Build-up of salts on piston</p> <p>Mobile phase incompatible with seal material</p> <p>Note: <i>The UHMW-PE blend that is used by ASI is resistant to almost all HPLC solvents. However, there are a few solvents for which Teflon is more suitable. These are 100 % methylene chloride and 100 % toluene. Refer to catalog section on seals.</i></p>	<p>Replace with new piston.</p> <p>Use the piston flush option if available. Always run DI water through the pump before shutting down for the day when running buffers.</p> <p>Use a Teflon seal.</p>

AS/ HPLC Accessories



Table of Contents

In-Line Check Valves	111
Reference Manual for HPLC	111
Fittings and Unions	112
Filters	112
Tubing	114
High Pressure Metering Valve	114

In-Line Check Valves

The ASI in-line check valve incorporates many of the innovations of our self-priming replacement check valves. It is a rapid-closure cartridge valve that features very low resistance to flow, low internal volume, and operates independently of gravity. It is protected from solvent contamination by a 1/4" diameter 2 micron frit, and features crush-proof construction. The valve may be used whenever flow needs to be restricted to one direction. Applications include prevention of post column derivatization fluids from back-flowing into the column in the event of mobile phase pump failure. This valve is also available in a high temperature version that will operate at up to 125 °C and 5,000 PSI (Please call for more information).

Valve Specifications

ASI Part Number	250-2000 150-2005	250-2000UHP 150-2005UHP	250-2001 150-2006
Internal Volume	48 µL	48 µL	60 µL
Cracking Pressure	1.0 PSI	1.0 PSI	1.0 PSI
Maximum Operating Pressure	15,000 PSI	30,000 PSI	15,000 PSI
Cv*	0.005	0.005	0.02

*Cv of 1.0 is defined as one gallon per minute of 60 °F water resulting from a 1 PSI pressure drop.
1 gallon = 3,785 mL.

Description	ASI Part Number
In-Line Check Valve with 1/8" Ball Cartridge	250-2000
Replacement 1/8" Ball Cartridge	150-2005
In-Line Check Valve with 1/8" Ball Cartridge Ultra High Pressure	250-2000UHP
Replacement 1/8" Ball Cartridge Ultra High Pressure	150-2005UHP
In-Line Check Valve with 3/16" Ball Cartridge	250-2001
Replacement 3/16" Ball Cartridge	150-2006

Reference Manual for HPLC

This book should be used as a primary resource to:

- * Get started in any HPLC method with recommended procedures
- * Optimize methods using basic explanations
- * Troubleshoot instruments and methods with specific and general guides
- * Understand the basic chromatographic principles
- * Maximize operational factors including systems and detectors
- * Learn to prepare samples properly
- * Conform to accepted methods development and validation procedures
- * Choose appropriate capillary electrophoresis methods and implement them

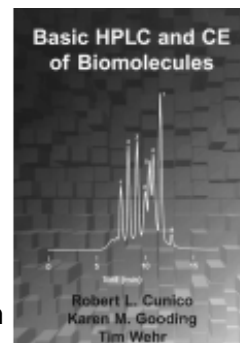

Title	ASI Part Number
Basic HPLC and CE of Biomolecules by Robert L. Cunico, Karen M. Gooding and Tim Wehr	RM-01

**American Library
Association
Book Award Winner**

Fittings, Unions

316 Stainless Steel Compression Fittings and Unions

Universal fittings and unions are compatible with most HPLC fittings such as Parker, Swagelok, Valco, Upchurch, Beckman, and Waters, when initially assembled with new ferrules. All components are manufactured from 316 stainless steel, and are cleaned and passivated. Unions come complete with 1/16" compression fittings.

Description	ASI Part Number
ZDV Straight Union 0.040" Thru	920-0624
ZDV Straight Union 0.020" Thru	920-0622
10-32 Compression Screw 1/16" Tube 10/Pack	900-0622
10-32 Compression Screw 1/16" Tube 25/Pack	900-0623
Ferrule for 1/16" Tube 10/Pack	910-0622
Ferrule for 1/16" Tube 25/Pack	910-0623

PEEK Finger Tite Fittings

Description	ASI Part Number
PEEK Finger Tite Fittings for 1/16" TFE, PEEK Tube	800-0630
PEEK Finger Tite Fittings for 1/16" TFE, PEEK Tube 10/Pack	800-0631

Filters

Solvent Inlet Filters

It is essential to use a solvent filter at the pump intake to insure reliable operation of the check valves and other pump system components. We recommend a 2 micron filter for most analytical applications. For flow rates in excess of 10 mL per minute, we recommend a 10 micron filter to avoid pump cavitation. ASI filters are designed to slip inside either 1/16" ID or 1/8" ID tubing, and are made from 316 stainless steel.

Description	ASI Part Number
10 micron Solvent Filter for 1/16" ID	850-0620
10 micron Solvent Filter for 1/16" ID 5/Pack	850-0621
2 micron Solvent Filter for 1/16" ID	850-0623
2 micron Solvent Filter for 1/16" ID 5/Pack	850-0625
10 micron Solvent Filter for 1/8" ID	850-1250
10 micron Solvent Filter for 1/8" ID 5/Pack	850-1251
2 micron Solvent Filter for 1/8" ID	850-1253
2 micron Solvent Filter for 1/8" ID 5/Pack	850-1255

In-Line Filters

Placed between the pump and injector, these filters protect the injector from pump seal wear material and extend the life of the column prefilter. All filters are made from 316 stainless steel and are rated to 15,000 PSI. Filters include 10-32 compression fittings.

High Capacity In-Line Filters

This filter features a clean-swept internal volume and a large 2.2 cm² filter area that will provide a long service life. Filter cartridges are available in 0.5 micron and 2 micron porosity, and are both interchangeable and replaceable. Total internal volume is 100 µL for 0.5 micron filter, and 120 µL for 2 micron filter.

Description	ASI Part Number
High Capacity In-Line Filter, 2 micron	850-1310
High Capacity In-Line Filter, 0.5 micron	850-1315
2 micron Replacement Filter Cartridge for HC	850-1320
0.5 micron Replacement Filter Cartridge for HC	850-1325

Low Volume In-Line Filters

Recommended for applications where system volume must be kept to a minimum. Filter cartridges are available in 0.5 micron and 2 micron porosity, are both interchangeable and replaceable, and have a 0.32 cm² active area. Full use of the filter surface is maintained by a 5° entrance cone. Total internal volume is 14 µL for the 0.5 micron filter and 18 µL for the 2 micron filter.

Description	ASI Part Number
Low Volume In-Line Filter, 2 micron	850-1330
Low Volume In-Line Filter, 0.5 micron	850-1335
2 micron Replacement Filter Cartridge for LV 5/Pack	850-1340
0.5 micron Replacement Filter Cartridge for LV 5/Pack	850-1345

Precolumn Filters

ASI column inlet filters are designed to protect the column from injector valve and pump seal wear material. The 0.094" diameter filter cartridge offers a relatively high filtering capacity with only moderate dispersion, and is recommended for conventional 4.6 mm columns. The 0.062" diameter filter cartridge offers moderate capacity with low dispersion, and is recommended for most microbore columns. Both cartridges are replaceable and interchangeable with each other.

Description	ASI Part Number
Precolumn Filter, 0.5 micron x 0.094" Filter	850-1350
Precolumn Filter, 0.5 micron x 0.062" Filter	850-1355
0.5 micron x 0.094" Replacement Filter Cartridge 5/Pack	850-1360
0.5 micron x 0.062" Replacement Filter Cartridge 5/Pack	850-1365

Tubing

1/16 " OD Stainless Steel Capillary

ASI Capillary tubing is made from 316 stainless steel and is available in 25 ft. lengths; other lengths upon request. The tubing ID should be passivated after cutting as follows: 20 % nitric acid for 30 minutes, followed by distilled water rinse.

Description	ASI Part Number
SS Tubing 1/16" OD x 0.010" ID x 25 ft	800-0010
SS Tubing 1/16" OD x 0.020" ID x 25 ft	800-0020

Teflon (TFE) Tubing

Teflon Tubing provides unmatched solvent resistance for low pressure applications.

Description	ASI Part Number
Teflon (TFE) Tubing 1/16" OD x 0.030" ID x 25 ft	810-0030
Teflon (TFE) Tubing 1/8" OD x 1/16" ID x 25 ft	810-0063
Teflon (TFE) Thinwall Tubing 1/8" ID x 25 ft	810-0125

PEEK Tubing

PEEK can be substituted for stainless steel tubing when contact with metal is a concern. It is inert to most HPLC solvents, will withstand intermittent operation up to 5,000 PSI, and continuous operation at 4,000 PSI. PEEK tubing should not be used at these pressures with DMSO, THF, or methylene chloride.

Description	ASI Part Number
PEEK Tubing 1/16" OD x 0.005" ID x 5 ft	820-0631
PEEK Tubing 1/16" OD x 0.010" ID x 5 ft	820-0632
PEEK Tubing 1/16" OD x 0.020" ID x 5 ft	820-0630

High Pressure Metering Valve

The High Pressure Adjustable Metering Valve maintains a back pressure which is directly proportional to the inlet flow rate and solvent viscosity. The valve has an adjustment range from 10 PSI to 5,000 PSI at 1.00 mL/min. with water. The dead volume is less than 4 µL with flow paths designed to minimize dispersion.



Description	ASI Part Number
High Pressure Metering Valve	690-0000

**The following trademarks and registered trademarks
are found in this catalog.**

ABI	Kratos International
Agilent	Hewlett-Packard Co.
Beckman	Beckman Instruments
Beckman System Gold	Beckman Instruments
Bio-Rad	Bio-Rad Laboratories
Eldex	Eldex Laboratories
Gilson	Gilson, Inc.
Hitachi	Hitachi
Kel-F	3M Company
PEEK	Victrex plc
Perkin Elmer	Perkin Elmer Corp.
Shimadzu	Shimadzu Scientific Instruments
Spectra Physics	ThermoQuest
Teflon	E.I. duPont Co.
TSP	ThermoQuest
TSP Spectra Vision	ThermoQuest
Varian	Varian Analytical Instruments
Varian LC Star	Varian Analytical Instruments
Waters	Waters Corp.

The trademarks referred to are the property of their respective owners.

Analytical Scientific Instruments, Inc.

distributed by Socochim SA for Switzerland

<http://www.socochim.ch> email: info@socochim.ch

Phone: 021 721 04 50 Fax: 021 721 04 51

